

ANNUAL  
**LOGISTICS  
EDUCATION**  
ISSUE

# inbound • logistics

a **THOMAS**™ company

THE MAGAZINE FOR DEMAND-DRIVEN LOGISTICS • FEBRUARY 2018

**SUPPLY**  
**U**  
**CHAIN**

TOP  
CAREER  
SKILLS

Got 3PL challenges?

Get free expert solutions at [inboundlogistics.com/3pl](http://inboundlogistics.com/3pl)



# FUTUREPROOF YOUR SUPPLY CHAIN AT MODEX 2018

Whatever manufacturing and supply chain solutions or insights you need to FUTUREPROOF your business, you'll find them at MODEX 2018.

With over 850 of the industry's solution providers on site and more than 100 hands-on education sessions, MODEX 2018 allows you to make new contacts, discover cutting-edge solutions and learn the latest trends that are sure to give you a leg up on the competition.



Georgia World Congress Center  
Atlanta, Georgia  
April 9-12, 2018

THE GREATEST SUPPLY CHAIN  
SHOW ON EARTH.®

## MODEX Keynotes:

**Monday, April 9**  
**8:45 AM – 9:30 AM**

Anticipating  
Tomorrow's Supply  
Chain Challenges – Today

**JUAN PEREZ**  
Chief Information and  
Engineering Officer, UPS

**Monday, April 9**  
**9:30 AM – 10:00 AM**

Welcome to MODEX 2018  
**GOVERNOR NATHAN DEAL**  
Governor of Georgia

**Tuesday, April 10**  
**8:45 AM – 9:45 AM**

Harnessing Our  
Digital Future  
How the Digital  
Revolution is Accelerating  
Innovation, Driving  
Productivity and Irreversibly  
Transforming Employment  
and the Economy

**ANDREW MCAFFEE**  
Co-Founder &  
Co-Director, Initiative  
on the Digital Economy

**Wednesday, April 11**  
**8:45 AM – 9:45 AM**

2018 MHI Annual Industry  
Report Keynote Panel

**GEORGE W. PREST**  
CEO, MHI

**SCOTT SOPHER**  
Principal, Deloitte  
Consulting LLP

**Wednesday, April 11**  
**1:00 PM – 2:00 PM**

Why Dirty Jobs Matter



**MIKE ROWE**  
Founder,  
mikeroweWORKS Foundation

**MODEX is FREE to attend.**

**LEARN MORE AND REGISTER AT [MODEXSHOW.COM](http://MODEXSHOW.COM).**

Got 3PL challenges?

Get free expert solutions at [inboundlogistics.com/3pl](http://inboundlogistics.com/3pl)

# info snacks

BITE SIZED SUPPLY CHAIN/LOGISTICS INFORMATION

## \$80,000 per hour

The amount of money shipping companies and The Port of Rotterdam expect to save as a result of IBM's digitization strategy.

(See *Global*, p. 27)

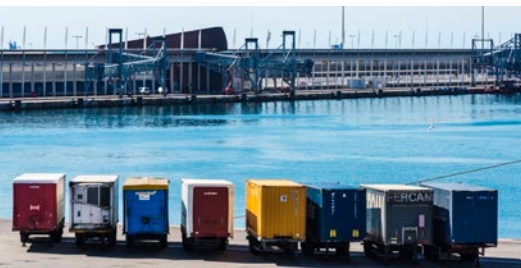

Provide driver parking  
Be quick about loading  
Stay open nights

The best ways to deal with rising truckload prices and avoid self-sabotage, according to Timothy G. Taylor, ShippersEdgeTMS.com

(See *Viewpoint*, p. 32)

## Rail intermodal

The fastest-growing mode, rising 50.6% from June 2009 to December 2016. Trucking grew the second fastest at 37.8%, followed by pipeline at 29.6%, waterborne at 23.2%, and air freight at 21.7%

— *Transportation Economic Trends 2017*, U.S. Department of Transportation report

## “Average is for other people.”

—Derek Leathers, President and CEO, Werner Enterprises on his goal to build an organization where each individual, at each job level, believes in and aspires to being well above average.

(See *Leadership*, p. 14)



# 60%

The number of small businesses that shut down within six months of losing data.

—2017 Clutch study

# 51%

The number of mid-sized companies that close down within two years of encountering a major data breakdown.

—Gartner study

**CUSTOMIZABLE SUPPLY CHAINS:  
FIT TO A T**  
page 54



# inbound logistics

a THOMAS company THE MAGAZINE FOR DEMAND-DRIVEN LOGISTICS

February 2018 • Vol. 38 • No. 2

- 6 CHECKING IN**  
*The human experience.*
- 8 DIALOG**  
*The ongoing conversation.*
- 10 GOOD QUESTION**  
*With no budget restrictions, what would you buy?*
- 12 10 TIPS**  
*Choosing a 3PL.*
- 14 LEADERSHIP**  
*Derek Leathers of Werner Enterprises shares his vision.*
- 30 SPONSORED KNOWLEDGEBASE**  
*Want to run a more successful 3PL? Learn from the best.*
- 32 VIEWPOINT**  
*Contain rising truckload prices.*
- 34 TRADE COMPLIANCE STRATEGIST**  
*Yes, NAFTA affects you too.*
- 36 ECODEV**  
*How Georgia designed an innovative logistics landscape.*
- 80 LAST MILE: LEXICON LAUGHS**

## INFO

- 1** INFO SNACKS
- 19** NOTED
- 23** TRENDS

- 27** GLOBAL
- 68** WEB\_CITE CITY
- 70** WHITEPAPER DIGEST

- 72** IN BRIEF
- 76** CALENDAR
- 77** SUPPLY CHAIN SOLUTIONS

- 78** RESOURCE CENTER

## INPRACTICE

- 16 READER PROFILE** **Howie Mann: Helping to Train a New Generation**  
Supply chain high school founder Howie Mann delivers lessons about logistics.



- 65 CASEBOOK** **Sourcing Packaging Globally Boxes Up Savings**  
Hungry to reduce food packaging costs, Church's Chicken flies the coop on domestic packaging suppliers and sources across the globe.

## INDEPTH

- 38 Core Competencies Every Supply Chain Manager Needs**  
Acquire these skills to build success for your company, and your career.
- 48 Logistics and Supply Chain Education Resource Guide**  
Use this guide to find schools and associations with logistics, supply chain, and transportation education offerings.
- 54 Customizable Supply Chains: Fit To a T**  
The specifics of tailoring a supply chain where no two items are the same, and everything is taken personally.
- 60 6 Supply Chain Terms Creating Buzz**  
Speak the language of logistics by learning these industry terms.

Inbound Logistics (ISSN 0888-8493, USPS 703990) is mailed monthly to approximately 60,000 business professionals who buy, specify, or recommend logistics technology, transportation, and related services, by Thomas Publishing Company LLC, 5 Penn Plaza, NY, NY 10001. José E. Andrade, co-chairman; Carl T. Holst-Knudsen, co-chairman. Periodicals postage paid at New York, NY, and additional mailing offices. All rights reserved. The publisher accepts no responsibility for the validity of claims of any products or services described. No part of this publication may be reproduced or transmitted in any form or by any electronic means, or stored in any information retrieval system, without permission from the publisher. POSTMASTER SEND ADDRESS CHANGES TO: Inbound Logistics, 5 Penn Plaza, New York, NY 10001

2 Inbound Logistics • February 2018

Got 3PL challenges?

Get free expert solutions at [inboundlogistics.com/3pl](http://inboundlogistics.com/3pl)

*Only pay for the speed you need...  
Dynamic Routing!<sup>SM</sup>*



### **On time and on budget.**

At Lynden, we understand that plans change but deadlines don't. That's why we proudly offer our exclusive Dynamic Routing system. Designed to work around your unique requirements, Dynamic Routing allows you to choose the mode of transportation – air, sea or land – to control the speed of your deliveries so they arrive just as they are needed. With Lynden you only pay for the speed you need!

**LYNDEN**  
Innovative Transportation Solutions

lynden.com | 1-888-596-3361

Got 3PL challenges?

Get free expert solutions at [inboundlogistics.com/3pl](http://inboundlogistics.com/3pl)

## 5 THINGS TO CONSIDER WHEN CHOOSING AN ELD PROVIDER

[bit.ly/ELD\\_Provider](http://bit.ly/ELD_Provider)



# inbound logistics

a **ii** THOMAS™ company

## QUICKBYTES

### LOGISTICS & SUPPLY CHAIN NEWS

For up-to-the-minute information, bookmark the *IL* news page. Enjoy opinions, commentary, and the latest news to help you stay on top of your game.

[bit.ly/IL-news](http://bit.ly/IL-news)

### INBOUND LOGISTICS PODCAST

The *IL* Podcast provides the most relevant and topical information from the third-party logistics and supply chain management world as presented by influential thought leaders in the industry.

[bit.ly/ILMagPodcastPage](http://bit.ly/ILMagPodcastPage)

### WEB\_CITE CITY®

The most comprehensive and clutter-free online directory of supply chain websites – organized by category, cross-referenced, and fully searchable. You can browse by category or search for companies by name.

[bit.ly/IL\\_WCC](http://bit.ly/IL_WCC)

## ONLINE COMMENTARY



### 5 Things to Consider When Choosing an ELD Provider [bit.ly/ELD\\_Provider](http://bit.ly/ELD_Provider)

Now that the ELD mandate has taken effect, grabbing a logging device off the shelf may seem like a quick and effective fix. It's not. Here's what to look for when making this critical selection.



### Supply Chain Collaboration: Myth or Reality?

[bit.ly/SC\\_Collaboration](http://bit.ly/SC_Collaboration)

Supply chain collaboration is vital for companies to make critical decisions quickly and outpace the competition. But are the key concepts of collaboration a current reality or a myth? This article breaks them down.



### 4 Common Fees to Monitor For Supply Chain Savings

[bit.ly/SC\\_Savings](http://bit.ly/SC_Savings)

Maintain a healthy network, and reduce unnecessary and often avoidable fees, with these four simple key performance indicators.

FOR MORE NEWS, TRENDS, AND COMMENTARY  
SEE [INBOUNDLOGISTICS.COM](http://INBOUNDLOGISTICS.COM)



### Keep up to date with the very latest:

[bit.ly/ILMagPodcastPage](http://bit.ly/ILMagPodcastPage)

[facebook.com/InboundLogistics](https://www.facebook.com/InboundLogistics)

[@ILMagazine](https://twitter.com/ILMagazine)

[linkedin.com/company/inbound-logistics](https://www.linkedin.com/company/inbound-logistics)

[youtube.com/user/InboundLogistics](https://www.youtube.com/user/InboundLogistics)

## EDUCATION RESOURCES

### Find an Education Program

[bit.ly/DST\\_EDU](http://bit.ly/DST_EDU)

The Logistics and Supply Chain Education Decision Support Tool will help you find learning opportunities from leading logistics institutions.

### Education Request for Proposal [bit.ly/EDURFP](http://bit.ly/EDURFP)

Use this Education RFP to contact leading universities and professional institutions that can help you improve your logistics and supply chain skillsets.



# Serving the Manufacturing Industry with over 23 years of experience and efficiency!

## Advantages and Benefits:

- Paid overtime for expedited commercial crossings
- Continued education through informative trade sessions
- Secured commercial cargo programs: FAST Lane, C-TPAT, ACE
- Southbound crossing discounts
- Professional staff ready to assist
- Established loyal customer base
- Ranked #5 for manufactured goods
- Plans for new commercial entry/exit lanes
- Plans for gate to gate connector
- Plans for dock expansion
- Excellence in regional logistics

## **#5 Manufactured Goods Bridge in the Nation**



**Pharr**  
International Bridge

[www.PHARRBRIDGE.com](http://www.PHARRBRIDGE.com)  
(956) 402-4660

*Your Connection. Your Business. Your Bridge.*

Got 3PL challenges?

Get free expert solutions at [inboundlogistics.com/3pl](http://inboundlogistics.com/3pl)

# CHECKING IN



by Keith Biondo | **Publisher**



## STAFF

**PUBLISHER** Keith G. Biondo  
publisher@inboundlogistics.com

**EDITOR** Felecia J. Stratton  
editor@inboundlogistics.com

**MANAGING EDITOR** Lauren Muskett  
lmuskett@inboundlogistics.com

**SENIOR ASSOCIATE EDITOR** Katrina C. Arabe  
karabe@inboundlogistics.com

**CONTRIBUTING EDITORS**  
Merrill Douglas • Karen M. Kroll  
Gary Frantz • Tamar Chapman • Emma James

**CREATIVE DIRECTOR** Jeof Vita  
jvita@inboundlogistics.com

**MULTIMEDIA CONTENT DESIGNER** Evelyn Klotz  
eklotz@inboundlogistics.com

**DIGITAL DESIGN MANAGER** Amy Palmisano  
apalmisano@inboundlogistics.com

**PUBLICATION MANAGER** Sonia Casiano  
sonia@inboundlogistics.com

**CIRCULATION DIRECTOR** Carolyn Smolin

**PUBLISHING ASSISTANT** Kathy Narvaez

## SALES OFFICES

**PUBLISHER: Keith Biondo**  
212-629-1560 • FAX: 212-629-1565  
publisher@inboundlogistics.com

**WEST/MIDWEST/SOUTHWEST: Harold L. Leddy**  
847-446-8764 • FAX: 847-305-5890  
haroldleddy@inboundlogistics.com

**Marshall Leddy**  
612-234-7436 • FAX: 847-305-5890  
marshall@inboundlogistics.com

**SOUTHEAST: Gordon H. Harper**  
404-229-9691 • FAX: 404-355-2036  
south@inboundlogistics.com

**MIDWEST/ECONOMIC DEVELOPMENT: Joseph Biondo**  
516-578-8924  
jbiondo@inboundlogistics.com

**NORTHEAST: Rachael Sprinz**  
212-629-1560 • FAX: 212-629-1565  
rachael@inboundlogistics.com

**NATIONAL SALES ASSOCIATE: Nicole Mangray**  
212-290-8757  
nicole@inboundlogistics.com

## FREE SUBSCRIPTIONS

[www.inboundlogistics.com/free](http://www.inboundlogistics.com/free)



Inbound Logistics supports sustainable best practices. Our mission is rooted in helping companies match demand to supply, eliminating waste from the supply chain. This magazine is printed on paper sourced from fast growth renewable timber.

Inbound Logistics welcomes comments and submissions. Email us at [editorial@inboundlogistics.com](mailto:editorial@inboundlogistics.com); call (212) 629-1560; or mail 5 Penn Plaza, NY, NY 10001. For advertising or subscription information, call (212) 629-1560, or e-mail [publisher@inboundlogistics.com](mailto:publisher@inboundlogistics.com). Inbound Logistics is distributed without cost to those qualified in North America. Interested readers may subscribe online at [bit.ly/get\\_il](http://bit.ly/get_il). Subscription price to others in North America: \$95 per year. Foreign subscriptions: \$229. Single copy price: No. Amer. \$10, foreign \$19, back issues \$15.



## The Human Experience

I am adding something to the acronym alphabet soup: HX or the Human Experience. In the ever-evolving supply chain process—shaped by automation, co-bots, and the global search for the lowest skilled hourly wage—are the cards irrevocably stacked against the humanity who grind the operational logistics gears that make it all happen?

Recent developments in supply chain operations have me thinking about the impact that current and planned supply chain technology and practices have on the humans working the process—the HX. You are one of them. There are others.

We've all seen and heard many stories of how Hours of Service regulations impact the mindset of OTR drivers. Combine those rules with the ELD mandate, and many OTR and OO free spirits say their independence has disappeared and seemingly melded into the machine they are atop of.

Business owners and shippers understandably want to bring order to the occasional chaos that moving billions of shipments entails. But in that flow you can't program for every variable. At least not yet. But Amazon recently filed a patent for a FitBit-like bracelet that all warehouse workers would wear to track every hand gesture. Think of it as a HX ELD.

One national brand is "datafying its employees to death" by implementing an Order-to-Shelf (OTS) regime, according to press reports. "I wake up in the middle of the night from nightmares about maps and inventory," says one store manager. "The stress has created such a tense working environment. Seeing someone cry at work is becoming normal." Stringent inventory control has also created plenty of stock-outs, adding consumer anger directed at workers to the mix.

The past holiday season brought reports of exhausted fulfillment and warehouse workers; some falling asleep on their feet when being forced to work double shifts. Delivery drivers, those ironically not subject to HoS regulations, were pressed to physical limits by having to take care of business on the go—if you get my drift.

I can't ever recall a mainstream, national conversation about the plight of workers, programs for workforce training, hourly raises, bonuses, new plants, more hiring, and wealth sharing. Respect for the everyday worker, with the possible exception of Mike Rowe and *Dirty Jobs*, is usually all hidden. That's especially true in behind-the-scenes supply chain operations.

So, in the rush to satisfy ever-increasing demands for speed and efficiency, and clarion calls to deliver your best Customer Experience (CX), consider the impact on the human experience. Because in the end, even with the best technology, it's still HX that will drive your CX. ■





**ADVANCE YOUR BUSINESS WITH THE  
FAR-REACHING RESOURCES WITH  
DLS WORLDWIDE'S  
LEVERAGED PLATFORM**



**AGENT OPPORTUNITIES**

**DLS Worldwide is in search of qualified stations and  
commissioned agents in select markets.**

**For additional information E-mail [agentinquiry@dls-ww.com](mailto:agentinquiry@dls-ww.com)**





© 1998 - 2017 R.R. Donnelley & Sons Company, all rights reserved. RR DONNELLEY, RRD, RRD (Stylized) and COMMUNICATIONS ENABLED are trade-marks or registered trademarks of R. R. Donnelley & Sons Company. All other trademarks are the property of R. R. Donnelley or their respective owners.

**Got 3PL challenges?**

**Get free expert solutions at [inboundlogistics.com/3pl](http://inboundlogistics.com/3pl)**

Want to join the conversation?

Follow us:

-  [linkedin.com/company/inbound-logistics](https://www.linkedin.com/company/inbound-logistics)
-  [facebook.com/InboundLogistics](https://www.facebook.com/InboundLogistics)
-  [twitter.com/ILMagazine](https://twitter.com/ILMagazine)
-  [youtube.com/user/InboundLogistics](https://www.youtube.com/user/InboundLogistics)
-  [www.inboundlogistics.com/cms/podcast](https://www.inboundlogistics.com/cms/podcast)

Drop us a line:

[editorial@inboundlogistics.com](mailto:editorial@inboundlogistics.com)

## Infrastructure Plan: Yay or Nay?

While the White House's plan kick starts this debate, it lacks the required federal investment. A proposal that relies on funding schemes like highway tolls and privatizing rest areas will not generate the revenue necessary to make significant infrastructure improvements.

New tolling on interstates is a non-starter. Tolls are ineffective, with as much as 33 percent of revenue wasted on administrative and overhead costs.

ATA has a solution to the funding question—the Build America Fund—which would generate \$340 billion over the next 10 years.

**Chris Spear**  
President and CEO  
American Trucking Associations

We are pleased the White House has made rebuilding American infrastructure a priority, and we look forward to working with members of Congress as they craft a final legislative package.

With freight volume projected to grow 45 percent over the next two decades, we need world-class ports and modern infrastructure to remain competitive. Failure to modernize our infrastructure could lead to a \$4-trillion loss of GDP by 2025 and increase the costs of consumer products by \$14 billion.

**Kurt Nagle**  
President and CEO  
American Association of  
Port Authorities

## How Readers Navigate the Driver Shortage

Rigid receiving windows at 24/7 distribution centers kill capacity. I had to charge an extra \$90/pallet earlier this month because two of my five stops at 24/7 DCs wouldn't even let me lump my own freight outside of an appointment. When rigid times cut truck capacity by 15 percent, rates go up.

**Glenn Kuehne, via LinkedIn**  
Owner/Driver  
Tortie Trails Trucking

If you'd like to do something about the driver shortage, call your senators and let them hear from you on the Hours-of-Service regulations. I came off the road three years ago. Too much hassle to run OTR anymore. Not enough money to be made. I'm making more money and home every day now.

**Jake Archer, via LinkedIn**  
Truck Driver, Peco Foods

The main issue has been the additional workload that goes into finding coverage for all our truck movements. Just this year alone, we have had several cases where truckers confirmed that a load was good to go in the morning only for them to cancel a few hours later. In some of these cases, it is entirely possible the drivers simply decided to take on another load that's more profitable.

**Klaus Lysdal, via email**  
Vice President of  
Sales and Operations  
iContainers

For a shortage to end, it will require an innovative way to lure the millennial generation away from less physically demanding desk jobs. Driverless technology notwithstanding, trucking companies must figure out a way to incentivize drivers through salary, positive shipper relationships, improved healthcare benefits, ease of entry into the industry, and forward-thinking workplace engagement.

**Justin Danks, via email**  
Carrier Sales Manager  
Sunset Transportation

## Planner Kudos

I just finished skimming through the latest *Logistics Planner*. It is a great edition. I cannot imagine the amount of blood, sweat, and tears that go into producing it.

**Cliff Lynch, via email**





**3** COASTS **7** PORTS  
**21** INTERMODAL TERMINALS

**1** CALL TO ACCESS THEM ALL.

1-888-668-4626 | [www.cn.ca](http://www.cn.ca) | [@CNRailway](https://twitter.com/CNRailway)

Got 3PL challenges?

Get free expert solutions at [inboundlogistics.com/3pl](http://inboundlogistics.com/3pl)

# Good Question...

READERS WEIGH IN

## If you could buy one product for your supply chain operations, with no budget restrictions, what would it be?



A time machine!

**Nick Williams**

*Key Supplier Manager  
General Dynamics Land Systems*

I would purchase a robust and mobile-enabled application that would allow any company in the world to place a purchase order and track it through every link in the global supply chain. While many applications today help support various silos within the supply chain, this technology would utilize the full power and mass availability of mobile phones, taking the supply chain to the next level.

**Micah Holst**

*President  
Marisol International,  
An Ascent Global Logistics  
Company*

Artificial intelligence (AI) has sharpened the competitive edge by predicting inefficiencies across the supply chain. Investing in solutions powered by AI that can analyze spend and identify opportunities for cost reduction, is an intelligent move, irrespective of budget.

**Andrew Nichols**

*Head of Procurement  
Tungsten Network*

We would purchase a robotic process automation (RPA) tool, hands down. While an RPA tool is a big upfront investment, the ROI has been proven and it's definitely on our radar for future system enhancements. When you're in a position of growth and your business's foundation is built, we see RPA as a terrific solution to maximize operational productivity.

**Lindsey Graves**

*Chief Operating Officer  
Sunset Transportation*

A forecasting solution. You know what they say: The difference between Bigfoot and an accurate forecast is Bigfoot has been spotted a couple of times.

**Robert Babak Izadpanah**

*MCN Business Analyst Nordics  
IKEA Group*

I'd buy technology products and software to digitize process and bring efficiency and accuracy, providing real-time information on shipment and record keeping for further audit and compliance. The ROI would be high, which could compare through cost-benefit analysis in the long run.

**Shyam Singh**

*Manager, Commercial  
Dimension Data*

A fully automated warehouse.

**Alberto Hausmann**

*Supply Chain Manager  
F.T. Industrial Supplies Ltd.*

Pizza.

**Nicholas Rutala**

*Operations Manager  
Genpact*

---

### HAVE A GREAT ANSWER TO A GOOD QUESTION?

Be sure to participate next month.

We want to know:

**Knowing what you know now about supply chain management, what advice would you give your younger self?**

We'll publish some answers.

Tell us at [editorial@inboundlogistics.com](mailto:editorial@inboundlogistics.com) or tweet us [#ILMagazine](https://twitter.com/ILMagazine) [#ILgoodquestion](https://twitter.com/ILgoodquestion)



Supply Chain | Truckload | LTL | Expedited | Intermodal | Air | Specialized

Your full-service 3PL backed by

# Game Changing Technology

Whatever the market conditions, R2 Logistics is your trusted partner for all modes of transportation. Arm yourself with the actionable data you need to drive efficiency and reduce cost with R2's cutting edge TMS platform. Our cloud-based TMS provides clients with the tools you need and ensures you are getting the right carrier for the right shipment at the right price.

[www.TheBest3PL.com](http://www.TheBest3PL.com) | [sales@r2logistics.com](mailto:sales@r2logistics.com)

Got 3PL challenges?

Get free expert solutions at [inboundlogistics.com/3pl](http://inboundlogistics.com/3pl)

# 10 TIPS

## STEP-BY-STEP SOLUTIONS



## Choosing a Third-Party Logistics Provider

**A** strong performing third-party logistics (3PL) provider can help you increase efficiency, control costs, and improve customer service. However, not all 3PLs are created equal. Tom Patterson, senior vice president of warehouse operations at Saddle Creek Logistics Services, recommends taking these steps and looking for certain characteristics to ensure you select a provider that can deliver.

**1 Do your research.** Whether you're selecting your first 3PL or changing providers, look for a company with proven processes, the right resources, and the ability to integrate with your systems.

**2 Establish a partnership.** Today's sophisticated logistics solutions require a high level of communication and data sharing. Find a 3PL you trust, with a compatible culture and values. Your partner should take time to understand your supply chain priorities.

**3 Look for a range of offerings.** The more help you obtain from a single provider, the more seamless and scalable your supply chain will be. With a range of capabilities, a 3PL can customize a solution to meet your needs.

**4 Ensure your 3PL has robust technology.** Your provider should offer advanced technology solutions. You may not need such sophisticated systems right now, but your business is always evolving.

**5 Aim for scalability.** A shared-space environment is a key advantage of outsourcing. The provider balances the needs of multiple customers so they can meet peak requirements without investing in permanent space, equipment, or labor. They also can scale operations to accommodate business needs.

**6 Determine customization capabilities.** An experienced 3PL can help you leverage postponement strategies to optimize inventory and deliver excellent service. Building to order instead of to stock allows you to cut production and inventory carrying costs.

**7 Find a provider that commits to continuous improvement.** Providers committed to service excellence and quality management pay careful attention to solution design and utilize proven processes to achieve desired results.

**8 Find a provider that offers omnichannel expertise.** Omnichannel retail is now mainstream. Select a provider that understands the nuances of omnichannel commerce and how to deliver the optimal customer experience. Look for an experienced partner with proven performance, a repeatable business model, and experience with your industry or business type.

**9 Choose a partner that maintains a network of locations.** An effective 3PL takes a strategic approach to network configuration and helps you determine the right distribution center locations for optimal efficiency for your current and future business. They'll have a network of conveniently located facilities—and the ability to open new locations to meet your specific needs.

**10 Seek stability.** When you partner with a 3PL, you entrust them with your brand, so it is important to find a company with a long history of proven success. Look for a financially stable partner that continues to invest in facilities, systems, equipment, and human resources necessary for optimal logistics solutions. ■

# Freightgate®

New Dimensions in e-Logistics



## Logistics Intelligence Takes you further!

- ✓ Empower Your People
- ✓ Better Decisions
- ✓ Faster Quotes
- ✓ Carbon Emission
- ✓ Better Customer Service
- ✓ Improved Bottom Line

## You can do more & stress less!

- ✓ Closing Ratios
- ✓ Customer Profiles
- ✓ Live Yield Calculation
- ✓ Customer Extranet
- ✓ Tender Management
- ✓ Invoice Audit

## End2End Visibility See 4 Yourself

- ✓ Line Item Detail
- ✓ Packing Lists
- ✓ Exception Management
- ✓ Email Alerts
- ✓ Vast Connectivity
- ✓ Unlimited Dashboards

## Call Freightgate Today!

- ✓ Gain immediate insights
- ✓ Learn why leading freight-companies prefer

### The Freightgate Cloud

- ✓ See how to quote in seconds
- ✓ Feel the power of dynamic routing

+1.714.799.2833  
Sales@freightgate.com

www.freightgate.com  
Logistics Cloud Solution

Got 3PL challenges?

Get free expert solutions at [inboundlogistics.com/3pl](http://inboundlogistics.com/3pl)

# LEADERSHIP

*Conversations With  
The Captains of Industry*

By Merrill Douglas

**Derek Leathers**  
President and CEO  
Werner Enterprises



## Average Is for Other People

**D**EREK LEATHERS EMBARKED ON HIS first big business venture when he was 12 years old. The scene was the circus, where his stepfather helped him get a job selling popcorn up and down the aisles.

“They weren’t able to employ me officially, but I got to keep whatever I made in tips,” Leathers says. “It was an opportunity to ‘eat what you kill’ from a competitive perspective. If your marketing, performance, and ability to serve the customer were better than others’, you made more money.”

Those lessons from the Big Top served Leathers well in his rise from trucking dispatcher to his current role: president and chief executive officer at Werner Enterprises. Leathers describes other forces that have influenced his leadership and shares his priorities at Werner today.

### **IL: How did you get into transportation and logistics?**

I majored in economics and finance at Princeton and was hired for a job in investment banking at Citi Corp. (now Citibank). But the company pushed back the starting date for new hires from the class of 1991 by six months. I couldn’t afford to go that long without a paycheck, so I applied to the only employer still doing interviews on campus, Schneider National. I took an entry-level job as a dispatcher. I planned to stay for only six months, but I fell in love with the industry.

I loved the opportunity to gain management experience and work with the independent spirits who get America’s goods to market on time every day, so the economy can grow. I loved the fact that what we were doing really mattered.

### **IL: What makes you an effective leader?**

The most important thing is having the ability to communicate with all levels of the organization and give them the message about why what they do matters. I love spending time with our drivers, but I’m equally comfortable in the boardroom or in our customers’ executive ranks. We do town hall meetings, both at our headquarters and across our terminal network. I’m constantly on the road, and any time I’m in a city where we have a terminal, it’s understood that our team will stop by to hold a driver meeting.

### **IL: What’s one early experience that shaped your career?**

As part of an executive management trainee program at Schneider, management asked me to go to Mexico and put my financial knowledge to work assessing a domestic Mexican trucking company that Schneider had bought. This business was failing; they wanted me to find out why. When I returned to headquarters and reported to our leadership, to my great surprise, they asked if I would be willing to go back and fix the problem. It was an opportunity of a lifetime for a person early in his career. So, with little preparation, I moved to Mexico City.



This was a unionized operation with about 300 trucks. Only one individual on site spoke English. I thought I spoke Spanish, but when it came to conducting meetings and trying to apply leadership in a foreign language, I had a lot of work to do. The experience forced me to improve my knowledge of the language and culture, and of transportation, at a much faster pace than I would have in the United States. I had to make mistakes, learn from them, and adapt.

**IL: What's one mistake you made there that taught you an important lesson?**

On several occasions, I was so eager to 'Schneiderize' the operation, I didn't realize that sticking to Schneider's core values, but adapting to the culture and country, would have been smarter. This taught me the importance of having mentors. I asked the company to set up an internal board of directors to oversee the Mexican operation, so I could gain insight and tutelage across human resources, maintenance, finance, and other disciplines. We included people from the U.S. corporate organization to advise me on all things Schneider and trucking. I also had a couple of people in Mexico who advised me on cultural issues and became lasting friends.

This experience offered an important lesson about leadership. You need to be transparent, to ask for help, and accept guidance, while also staying true to your own vision.

**IL: What is your top goal at Werner today?**

It's an unwavering commitment to excellence in everything we do. We have a saying around Werner that's on posters around the building: "Average is for other people." I want to build an organization where each individual, at each job level, really believes in and aspires to being well above average.

**IL: How do you nurture that value?**

You must reward behavior when it's apparent and visible. As a leader, you have to take the time to celebrate successes—illuminate them, so people know what success looks like. Also, you have to be diligent and absolutely unwavering in your expectations. Every opportunity, no matter how small it may be, when you notice the organization or an individual accepting an 'okay' outcome, or an average expectation, you have

to call it out. I do that not by attacking ideas or results, but by asking questions about whether this represents excellence. And if it doesn't, what are we going to do to improve?

**IL: What's the hardest aspect of your job?**

Having served as chief operating officer, then president, and now president and CEO, it's a challenge to give the new COO the autonomy to do his job, while not forgetting my role as mentor and coach when this person needs support. There are things the new COO will do better than I did, and other things that may require ongoing dialogue. Celebrating diversity of approach while retaining my right to expect improvement when needed requires a tough balance.

**IL: How do you cultivate talent in your organization?**

To cast the widest net possible, you need formal cultural training and development programs. If you rely only on those you interact with, or those you hear about, you will miss talent in your midst. We have a program called "18 Wheels to Success" for people who want to move up in their careers. They go through the 18 modules as their jobs and time allow. This gives us formal visibility into the up-and-comers and people who are looking to make a difference. ■

## Call Him Coach

"Coaches are the first real leaders kids are exposed to," Derek Leathers says, and that's why he devotes a major portion of his time outside work to youth sports.

As a student at Princeton University, Leathers played center for the Princeton Tigers football team. In 1997, he and several other Princeton alumni founded PlaySmart, a nonprofit that gives young people in grades 5 through 8 the chance to play sports and develop leadership skills. Leathers also coaches a nationally ranked traveling youth softball team and a youth football team.

"Kids generally say that other than their parents, coaches are the people with the greatest impact on their lives," Leathers says. "My philosophy around coaching is consistent with that belief. We spend more time on life skills and character than we do on actual techniques. The kids play at a very high level, but never at the expense of character, teamwork, honesty, or integrity."



**Howie Mann is a founder and board member with the Urban Assembly School for Global Commerce in New York City, which provides opportunities for economic mobility through access to college and career pathways in supply chain management and freight logistics.**

**RESPONSIBILITIES**

Helping to guide the school in its CTE (career and technical education) program, including curriculum and ongoing CTE activities, such as internships, ghosting with participating companies and agencies, and identifying resources to bolster the school's programs.

**EXPERIENCE**

Associate transportation analyst, New York Metropolitan Transportation Council; adjunct professor, Polytechnic Institute of New York University; planner, MTA Metro North Railroad.

**EDUCATION**

BA, City University Queens College, 1976; MS, transportation planning and engineering, Polytechnic Institute of New York, 1981.

## Howie Mann: Helping to Train a New Generation

**T**HE URBAN ASSEMBLY SCHOOL FOR GLOBAL Commerce started with a conversation. In 2010, I was talking with a labor statistics professional about positions in warehousing, transportation management, and logistics. The New York metropolitan region historically had very few jobs in these fields, as we weren't preparing students for them. Yet these are reliable jobs with good benefits, and they're not going to disappear.

That led to a further conversation with the Urban Assembly, an organization that helps create high schools. One thing led to another, and the Urban Assembly School for Global Commerce opened in 2013 in East Harlem. This is a full New York City school, staffed with New York City teachers, principals, and other staff.

The first graduating class was June 2017; more than three-quarters of starting students graduated in four years.

Graduation was the culmination of a huge effort, and it was wonderful.

Graduates can go directly into a related position, or they can further their education in supply chain, logistics, or transportation planning and engineering. About 80 percent of our first graduating class went on to college.

The board, faculty, principal, and industry partners give 100 percent to support the students, many of whom come

### The Big Questions

**Where have you traveled by train?**

All over. I've traveled the high-speed trains of Europe, including Italy, and the Eurostar from England to France, Germany, Belgium, and Switzerland. I've traveled across Canada, along the West Coast, and through the South by train.

**What books have left an impression?**

The books on my night table these days focus on the early days of World War II, including the Dunkirk evacuation. I'm

curious about it from both the logistics and the World War II aspects.

**What's the best leadership advice you've received?**

Be true to yourself, be fair to the people you work with, and at the same time, try to achieve your objectives.

**Before you retired, how would you have described your job to a five-year-old?**

In simple terms, I help people get things they need.

from families facing many challenges. They're focused on helping these students achieve things they didn't know they could.

I retired in 2015 after working for the New York Metropolitan Transportation Council (NYMTC), a metropolitan planning organization, as a principal freight planner. I produced, with the cooperation of many others, a body of work. While I was with NYMTC, my responsibilities included conducting and managing many studies.

One study looked at the potential development of freight villages around the NYMTC region. Freight villages are

concentrated areas of freight activity within specific borders. They bring together shippers, receivers, carriers, and manufacturers, so companies can take advantage of easy access to railroads and highways.

I also performed truck terminal and warehouse surveys, and a freight inventory. These efforts lay down a baseline of information on freight-related facilities in the area. Prior to these surveys, no one had this information.

When my brother and I were kids, our dad introduced us to trains. I saw these huge machines moving toward me, and it left a lasting impression.

I was looking for a career change, and found out Polytechnic Institute of New York had a program in transportation planning and engineering. I enrolled, loved it, and decided to make a career out of it.

I recognized early on that few people know anything about freight. Most are unaware of what's going on in the background: "Well, the package just shows up at my door."

Actually, it's a daily miracle all this activity takes place. I find it fascinating. I consider myself extremely fortunate that I've been able to spend a career working on something I enjoy so much. ■

## > FUTUREPROOF YOUR SUPPLY CHAIN AT MODEX 2018

**Industry 4.0 and the Industrial Internet of Things are here, and they're impacting manufacturing and supply chain operations every day.**

Whatever manufacturing and supply chain solutions or insights you need to FUTUREPROOF your business, you'll find them at MODEX 2018.

With over 850 of the industry's solution providers on site and more than 100 hands-on education sessions, MODEX 2018 allows you to make new contacts, discover cutting-edge solutions and learn the latest trends that are sure to give you a leg up on the competition.

MODEX is **FREE** to attend. Can you afford *not* to be here?



Georgia World Congress Center  
Atlanta, Georgia  
April 9-12, 2018

**THE GREATEST SUPPLY  
CHAIN SHOW ON EARTH.**

**LEARN MORE AND REGISTER AT [MODEXSHOW.COM](http://MODEXSHOW.COM)**

**Got 3PL challenges?**

Get **free** expert solutions at [inboundlogistics.com/3pl](http://inboundlogistics.com/3pl)

# Matson®

# Matson® LOGISTICS

## ***Expertise + Resources = Excellence***



**Hawaii**  
1-800-4MATSON  
[customerservice@matson.com](mailto:customerservice@matson.com)

**Guam, Micronesia, South Pacific**  
1-866-MNC GUAM  
[customerservice@matson.com](mailto:customerservice@matson.com)

**Alaska**  
1-877-678 SHIP  
[alaskacs@matson.com](mailto:alaskacs@matson.com)

**China**  
1-877-CHINA-02  
[phxchinasales@matson.com](mailto:phxchinasales@matson.com)

**Matson Logistics**  
1-866-628-7663  
[websales@matson.com](mailto:websales@matson.com)

**Got 3PL challenges?**

Get free expert solutions at [inboundlogistics.com/3pl](http://inboundlogistics.com/3pl)

# NOTED

THE SUPPLY CHAIN IN BRIEF

m&a

► **Sunset Transportation**, a third-party logistics company, acquired 3PL **Snowland Freight Services**, integrating its offices in Green Bay, Wisconsin, and St. Paul, Minnesota, to the Sunset network. The new branches, which operate under the Sunset Transportation name starting in February 2018, provide expanded coverage and support to Sunset's national freight network in the upper Midwest.

Flatbed transportation solutions provider **PS Logistics** acquired **Shelton Trucking Services**, which has approximately 200 drivers. The transaction strengthens PS Logistics' operations in the Southeast and provides additional terminals in Jacksonville, Florida, and Mobile, Alabama.

Software-as-a-Service logistics solutions provider **Descartes Systems Group** acquired **Aljex Software**, a cloud-based provider of transportation management solutions. Descartes will integrate Aljex into its Global Logistics Network to provide shippers with improved shipment tracking capabilities and access to carrier capacity.



## SEALED DEALS

▼ Meal kit delivery service **Sun Basket** chose sustainable box liners from **Sealed Air**, a provider of protective e-commerce packaging materials. In addition to using organic produce, sustainable ingredients, and recyclable packaging, Sun Basket wanted new insulation materials for its shipping boxes while retaining its commitment to 100-percent recyclable packaging. Sun Basket selected Sealed Air's TempGuard solution, a curbside recyclable box liner, to insulate its perishable products, ensuring contents maintain proper temperatures for one- and two-day ground shipping.



## SHOVEL READY

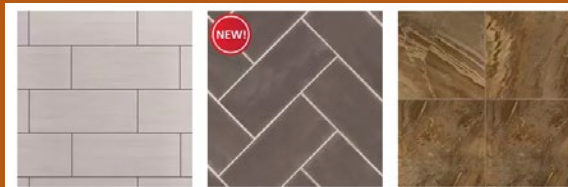

**Floor & Decor**, a specialty retailer of hard-surface flooring and related accessories, opened a 1.4-million-square-foot distribution center in Savannah. The new Floor & Decor facility sits on a 90-acre site and facilitates product storage and more efficient distribution to retail stores in the eastern United States. The complex, located near the intersection of Interstates 16 and 95, offers truck and rail access to the Port of Savannah, approximately 11 miles away.



**GREEN SEEDS**

**ID Label**, a manufacturer of custom barcode labels, committed to sending less than 1 percent of its waste to landfills, teaming up with Convergen Energy, a manufacturer of alternative fuels and power for sustainable business. By working with Convergen, the company will convert its waste—estimated at more than 500 tons per year—into fuel pellets, an alternative energy source, which can substitute for coal, gas, and other fossil fuels.



# recognition

Logistics solutions provider **Purolator International** won a **2018 Eggie Award** as tech-focused e-retailer Newegg's Best International Logistics Partner. This is the third consecutive year Purolator International has received this award, recognizing its employees across the United States and Canada for providing outstanding delivery service to Newegg's Canadian customers.

**Dachser USA Air & Sea Logistics** was named Chamberlain Group **Supplier of the Year**. Chamberlain Group, the parent company to LiftMaster, Chamberlain, Merlin, and Grifco, provides access solutions and products, designing and engineering residential garage door openers, commercial door operators, and gate entry systems. Through its 10-year collaboration with Dachser USA, Chamberlain Group has reduced logistics costs, improved lead times, and implemented risk improvement concepts, including supply chain contingency plans.

**SEALED DEALS**

Dog harness maker **Coastal Pet** collared **Indigo Software** to deploy *Indigo WMS* at its 400,000-square-foot manufacturing site in Ohio. The manufacturer of pet products, such as collars and leads, offers more than 7,500 unique products, serving B2B trade customers including large retailers and pet supply distributors. *Indigo WMS* is expected to bring real-time inventory accuracy by eliminating time delays between inventory transactions when items are either awaiting putaway or pre-picked and awaiting dispatch.



Lawn tractor and snow thrower maker **Ariens Company** renewed its contract with **Redwood Logistics** as its third-party logistics partner. Since their partnership started two and a half years ago, Redwood has delivered cost savings to the equipment maker using continual improvement initiatives, integrating all facets of its supply chain to facilitate data speed, accuracy, and visibility, and enable an overall increase in supply chain efficiency.

**UP THE CHAIN**

**Samuel A. Mills** was appointed vice president, integrated supply chain, with W. R. Grace & Co., a supplier of catalysts and engineered materials. Mills is responsible for the company's global manufacturing, procurement, order fulfillment, logistics, and supply chain planning activities.



**GOOD WORKS**

Freight brokerage firm **England Logistics** launched an initiative, in conjunction with parent company **C.R. England**, to feed one million hungry children per year beginning in 2018. The program focuses on addressing the needs of the millions of children in the United States without consistent access to adequate food. The company will donate proceeds from business transactions and fundraising efforts to youth programs at food banks across the nation.





# PUT **ELM** AT THE HELM

Established in 1980, **ELM Global Logistics** is your Northeast third-party logistics partner, with distribution facilities totaling more than 1 million square feet.

We offer dedicated or shared operations, along with a range of services including:

- **Cross-docking**
- **Reverse Logistics**
- **Pick & Pack**
- **Repackaging & Assembly**
- **Consolidation**

Long term or short term, we offer flexibility to support your logistics needs so you can focus on growing your business.

*Family Owned & Operated*

## **LOCATIONS**

**New York:** Brentwood  
& Ronkonkoma

**New Jersey:** Burlington

## **ELM GLOBAL LOGISTICS**

1.800.736.1771

Info@ELMLogistics.com

www.elmlogistics.com



Got 3PL challenges?

Get free expert solutions at [inboundlogistics.com/3pl](http://inboundlogistics.com/3pl)

WITH OVER 25 YEARS OF EXPERIENCE WE PROVIDE

# Personalized Service with Professional Expertise

An aerial view of a city at dusk or dawn, with a complex network of glowing orange lines and white location pins overlaid on the image, suggesting a global logistics network.

# SOLUTIONS. DELIVERED.

Brokerage | Committed Capacity Programs | Award Winning Transportation Management System | Outsourced Transportation Management | Shipping Across All Major Freight Modes

## [ The PLS Experience ]

PLS Logistics Services has been a trusted 3rd party logistics provider since 1991. Our industry professionals have worked with Fortune 500 companies from across all industries with varying capacity requirements. We are well versed in dynamic customer demands and have the flexibility to work with any size business. Our goal is to help clients increase transparency, gain access to capacity, and create operational improvements with competitive pricing.

*We know how to get it right, the first time.*

## CONTACT INFO:

[sales@plslogistics.com](mailto:sales@plslogistics.com)

[www.plslogistics.com](http://www.plslogistics.com)

**(888) 814-8486**



Got 3PL challenges?

Get free expert solutions at [inboundlogistics.com/3pl](http://inboundlogistics.com/3pl)



# Supply Chain Needs More Accurate Costing Information

Supply chain professionals need more accurate and effective cost information to help their decision-making, highlighting the need for supply chain and finance departments to work more closely together. They also need to adopt progressive costing practices that are focused on informing internal decisions.

That's according to a joint research report from APICS, the professional association for supply chain management, and IMA, the association of accountants and financial professionals in business.

Costing information also plays a critical role in sales and operations planning. Among those surveyed, supply chain managers agree, on average, that the benefits of improving their costing systems exceed the investment.

When asked what prevents them from utilizing current costing information, 44 percent of supply chain managers cite a lack of operational data. Instead, costing information is often reported in exclusively financial terms, making it more difficult to leverage.

The secondary and tertiary barriers to useful costing information are inadequate technology and software (39 percent) and a resistance to change by accounting and finance personnel (30 percent), according to respondents.

The report cites three root causes why supply chain professionals are not receiving adequate costing information:

**1 Relying too much on external financial reporting systems:** Many organizations rely on externally oriented financial accounting systems that employ oversimplified methods of costing products and services to produce

information supporting internal business decision-making.

**2 Using outdated costing models:** Traditional cost accounting practices can no longer meet the challenges of today's business environment, but many accountants still use them.

**3 Accounting and finance's resistance to change:** With little pressure from managers who use accounting information to improve data accuracy and relevance, accountants are reluctant to promote new, more appropriate practices within their organizations.

The report details various steps supply chain professionals can take to improve costing systems within their organizations. One strategy presented is for supply chain managers to strengthen their relationship with accounting and finance to foster greater information flow between the two departments.

Other solutions call for greater IT infrastructure and increased demand from top-level management for updated costing practices.

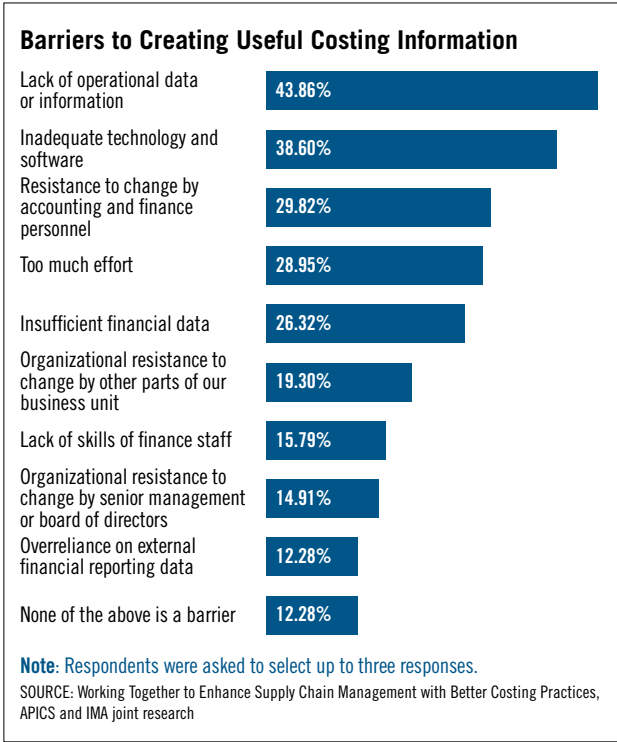

## Man vs. Machine

Business leaders are divided in how they envision the future of human-machine partnerships, according to global research from Dell Technologies. Half of the 3,800 global business leaders surveyed forecast that automated systems will free up their time, while the other 50 percent believe otherwise. Similarly, 42 percent believe they'll have more job satisfaction in the future by offloading tasks to machines, while 58 percent disagree.

Vanson Bourne conducted the quantitative research, which follows Dell Technologies' seminal story, *Realizing 2030: The Next Era of Human-Machine Partnerships*. That study forecasted that by 2030, emerging technologies will forge human partnerships with machines that are richer and more immersive than ever before, helping us surpass our limitations. Business leaders agree: 82 percent of respondents expect humans and machines will work as integrated teams within their organization inside of five years.

But leaders are also split on whether the future represents an opportunity or a threat, and torn by the need to mitigate these risks. For instance:

- 48 percent say the more we depend upon technology, the more we'll have to lose in the event of a cyber-attack; 52 percent aren't concerned.
- 50 percent of business leaders are calling for clear protocols in the event that autonomous machines fail; the other half abstained.
- 45 percent say computers will need to decipher between good and bad commands; 55 percent don't see a need.

Given the promise of monumental change—fuelled by exponentially increasing data and the applications, processing power, and connectivity to harness it—56 percent speculate that schools will need to teach how to learn rather than what to learn to prepare students for jobs that don't yet exist.

This thinking corroborates IFTF's forecast that 85 percent of jobs that will exist in 2030 haven't been invented yet.

# Guarding Your Business Against Data Loss

Data loss is every company's nightmare. In fact, most companies that do experience a mass disappearance of vital, computer-kept information never turn their lights on again.

It comes down to the idea that how you protect and treat your data is commensurate with how important you think it is, says Penny Garbus, co-founder of Soaring Eagle Consulting and co-author of *Mining New Gold: Managing Your Business Data*.

Companies both large and small often try to ensure the security of their IT infrastructure by outsourcing to a third-party security vendor. Garbus offers three main ways that managed security services can save a business from the disaster of data loss:

**1 Security check-ups.** These are essential for cyber security. The question you must ask is, how much downtime can my business afford? "One of the best ways to prevent cybersecurity issues is to have an expert conduct regular health checks on your system," Garbus says. "That

way if there are any lurking vulnerabilities or potential issues, they can be fixed before causing any damage."

**2 Performance measures.** This includes analysis of software, server, cloud, and firewall. Businesses these days operate in the realm of remote servers, cloud computing, and unrelenting security threats. "As the technological landscape evolves and data security has become increasingly important, businesses recognize there is much more to it than handling issues as they arise," Garbus says.

**3 IT development updates.** Hackers are becoming more sophisticated every day. For example, ransomware was able to stall private businesses, hospitals, universities, and government agencies. "If you're handling sensitive data, it's smart to upgrade the cybersecurity methods you've been using from the beginning of your business," Garbus says. "Small and mid-size companies aren't as likely to have a dedicated IT person to oversee the multiple systems, so it behooves them to have a service in place that can keep abreast of changing technology."

## A SLAP ON THE WRIST

Amazon has received two patents for a wristband system that monitors how warehouse workers move their hands.

Currently, when a product order is received, the details are transmitted to the handheld computers that all Amazon warehouse staff carry. The workers must then rush to retrieve that product from one of many inventory bins on shelves, pack it in a delivery box, and move on to the next assignment.

Amazon's proposed wristbands would emit ultrasonic pulses or radio transmissions to let a receiver system pinpoint the location of workers' hands in relation to inventory bins, and nudge them in the right direction, according to GeekWire.

The announcement has led to some negative feedback likening the wristbands to turning workers into human robots, or surveilling them to identify time-wasting activities.

However, "The speculation about this patent is misguided," Amazon said in an email to The Verge. "Every day at companies around the world, employees use handheld scanners to check inventory and fulfill orders. This idea, if implemented in the future, would improve the process for our fulfillment associates. By moving equipment to associates' wrists, we could free up their hands from scanners and their eyes from computer screens."

"Like most companies, we have performance expectations for every Amazon employee and we measure actual performance against those expectations, and they are not designed to track employees or limit their abilities to take breaks," Amazon said.

To date, this is just a patent filing, so there's no indication that using haptic feedback to guide workers' hands to the right place is the answer to improved productivity.

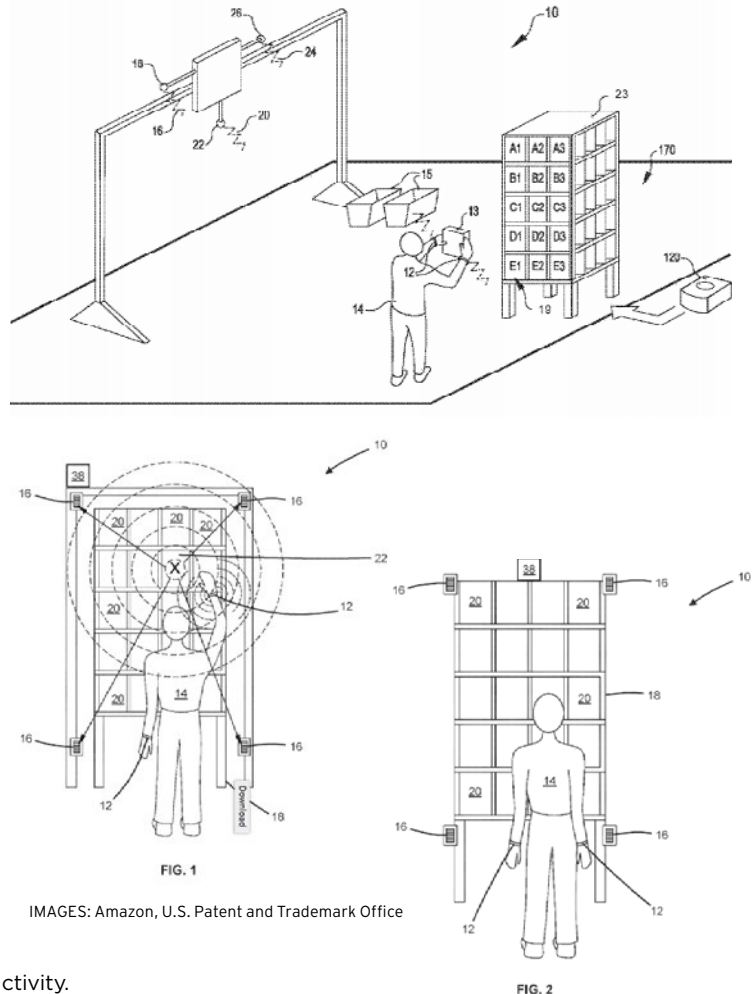

IMAGES: Amazon, U.S. Patent and Trademark Office



## You Can't Control Mother Nature, But You Can Be Ready For It

For senior financial executives at large U.S.-based companies with operations in Texas, Florida, or Puerto Rico, the 2017 hurricane season served as a risk management wake-up call.

Commercial and industrial property insurer FM Global surveyed these executives at companies with more than \$1 billion in revenue and found:

- Nearly two-thirds (64 percent) of respondents say 2017's hurricane season had an adverse impact on operations.
- Of those impacted, 62 percent admit they were not completely prepared to deal with the effects of the hurricanes.
- Nearly 7 in 10 (68 percent) of all respondents say they will make changes to their risk management strategy going forward.

As a result of hurricanes Harvey, Irma and Maria:

- 57 percent of all survey respondents say they will put in place or enhance their business continuity or disaster recovery plans.
- 40 percent will invest more in risk management, property loss prevention, and/or reassess their supply chain risk management strategy.
- 25 percent will reassess their insurance coverage or their insurers.

"One reason for insufficient natural-hazard preparation is imprecise terminology," says Dr. Louis Gritzko, vice president, manager of research at FM Global. For example, being in a "100-year flood" zone does not mean you have 99 years to plan. Rather, there's a one-percent chance of such a flood every year.

Another reason for insufficient preparation is over-reliance on insurance, which cannot restore market share, brand equity, and shareholder value lost to competitors. A third reason is denial of risk.



## INTERMODAL DELIVERS IN 2017

Intermodal freight volumes posted a fourth-quarter growth rate of 5.8 percent year-over-year, according to the Intermodal Association of North America's (IANA) fourth quarter and year-end *Intermodal Market Trends & Statistics* report. International volume increased by 7.7 percent; domestic containers grew by a modest 2.5 percent; while trailer loads increased by 12.2 percent.

"The imbalance between imports and international volumes in 2016 has reversed, resulting in a strong 4.7-percent volume gain for the year," says Joni Casey, president and CEO of IANA.

In this fourth quarter, the seven highest-density trade corridors accounted for 62 percent of total volume and were up collectively 3.7 percent.

- The Eastern-Western Canada corridor expanded by 12.7 percent, exceeding all other lanes by a wide margin.
- The Northeast-Midwest and the South Central-Southwest reached five-percent growth.
- The Midwest-Southwest, intra-Southeast, and Southeast-Southwest lanes recorded growth of 2.4 percent, 2.2 percent, and one percent, respectively.
- The Midwest-Northwest corridor volume shrank 5.2 percent, the only lane reflecting a decrease in volume.

Traffic for Intermodal Marketing Companies increased 16.8 percent year-over-year in Q4; almost all that gain took place in the highway segment.

This is the second consecutive quarter when both intermodal and highway loadings increased. For the full year, IMC volumes were up 5.4 percent, with highway moves growing at about twice the pace of intermodal loadings, IANA reports.

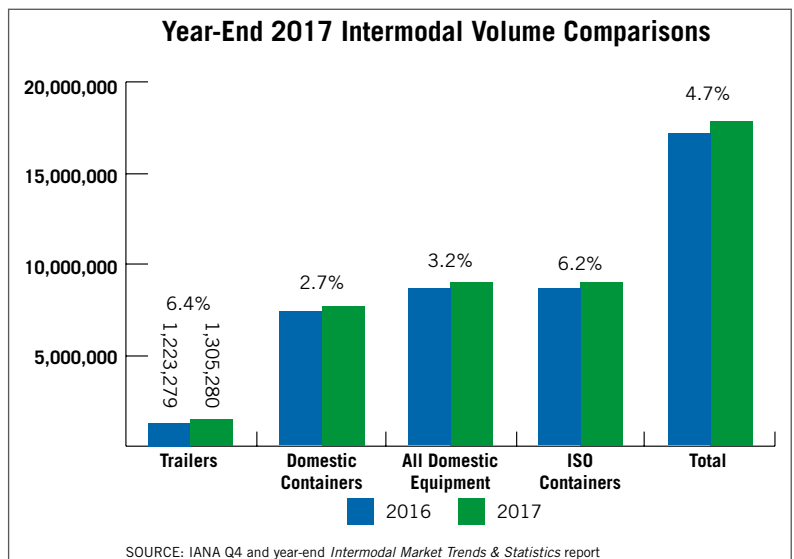



LOS ANGELES AREA  
CHAMBER OF COMMERCE



Celebrating a month  
of world trade in May

# 92ND ANNUAL WORLD TRADE WEEK KICKOFF BREAKFAST SOUTHERN CALIFORNIA: THE EVOLUTION OF TRADE IN A DIGITAL WORLD

**For 91 years, World Trade Week has been the most extensive and unique program of its kind in the country.**

Join more than 800 executives and members of the diplomatic corps to commence a month-long celebration of world trade in Southern California.

Opportunities now available to sponsor scholarships for high school and university students preparing for a profession in international trade.

**CORPORATE TABLES AVAILABLE!**



## SAVE THE DATE

FRIDAY, MAY 4 • INTERCONTINENTAL LOS ANGELES DOWNTOWN



KEYNOTE SPEAKER

# LAURIE TOLSON

CHIEF DIGITAL OFFICER, GE TRANSPORTATION

FEATURING A CONVERSATION WITH SPECIAL GUEST:

ACTING COMMISSIONER  
KEVIN MCALEENAN

U.S. CUSTOMS AND BORDER PROTECTION



**REGISTER NOW AT [LACHAMBER.COM/EVENTS](http://LACHAMBER.COM/EVENTS)**

For more information, contact Jasmin Sakai-Gonzalez, 213.580.7569 or [jgonzalez@lachamber.com](mailto:jgonzalez@lachamber.com). | [worldtradeweek.com](http://worldtradeweek.com)

Got 3PL challenges?

Get free expert solutions at [inboundlogistics.com/3pl](http://inboundlogistics.com/3pl)

## Raising the GPA

**GEORGIA PORTS AUTHORITY (GPA) HAS** developed a strategic plan that allows for 10 million twenty-foot equivalent container units, one million rail lifts, and more than one million auto and machinery units per year, GPA Executive Director Griff Lynch told attendees at the 50th annual Georgia Foreign Trade Conference in early February.

Lynch provided an overview of Georgia Port Authority's 2028 Plan that calls for 42 ship-to-shore cranes, 200 yard cranes, new rubber-tired gantry crane lanes, and significant intermodal expansion in Savannah. The GPA will soon open its second inland terminal in Northwest Georgia, and break ground on the Mason Mega Rail project at Garden City Terminal. Combined, both intermodal projects will open new markets while significantly reducing rail crossings and over-the-road freight through Savannah, Atlanta, and beyond.

GPA goals over the next few years include:

- 1** Double the volume of container rail lifts to one million.
- 2** Add eight more truck lanes to reduce transit times leaving the port.
- 3** Add temperature plugs for additional temperature control containers.
- 4** Grow to be the largest car port in the country.
- 5** Open new inland ports in North Georgia.

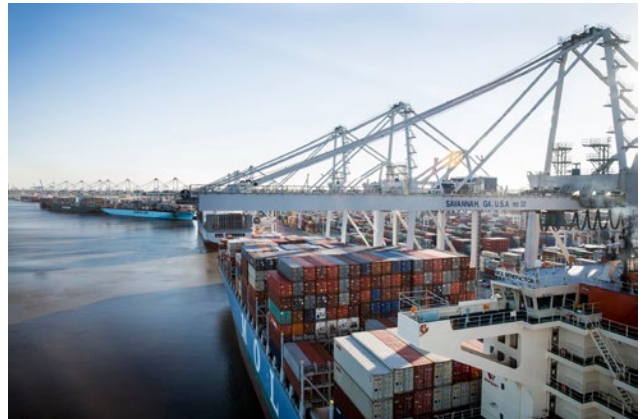

## Taking the Measure of Global Trade

### DHL Global Trade Barometer World Index 2013-present, 50 = no change

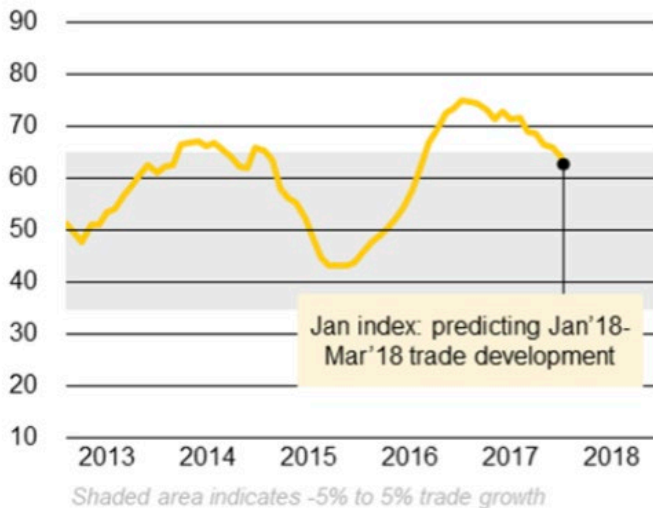

**CROSS-BORDER TRADE OF INTERMEDIATE** goods and early-cycle commodities point to a moderate increase in world trade through March 2018, according to the DHL Global Trade Barometer for January 2018. On its initial release, the index scored 64, which is slightly below the values calculated for previous months (*see chart*). That means that world trade is still considered to be in a growth mode, but that growth is losing momentum. The index attributes the decline to weakening prospects for Chinese and Japanese trade, which is only partially offset by improved prospects for India, South Korea, and Great Britain.

The DHL Global Trade Barometer derives predictions for global trade by evaluating large amounts of logistics data with the help of Artificial Intelligence. Since global trade fuels the world economy, the DHL Global Trade Barometer not only provides an outlook on future trade, but also on prospects for the global economy.

The index was jointly developed by DHL and Accenture, and will be published quarterly.

## The Model Port of the Future



**THE PORT OF ROTTERDAM**, Europe’s largest port, is working with IBM on a long-term digitization strategy that will transform the port—not only to improve safety and efficiency today, but also to accommodate autonomous ships, as well as process and ship metal 3D-printed ship components on demand in the future.

Key elements of the digitization strategy include:

- IoT-enabled sensors and AI capabilities will measure and analyze weather, water, and communications data from IBM’s The Weather Company. Data insights will be used to reduce wait times, allow more ships to enter the port, and predict the best time, based on water level, for a ship to arrive and depart Rotterdam with the maximum volume of cargo loaded on board.
- IBM IoT technologies will power a single dashboard that displays real-time data from multiple parties—terminal operator, ship’s captain, the port—enabling safer and more efficient traffic management at the port.
- Shipping companies and the port stand to save up to one hour in berthing time, which can amount to about \$80,000 per hour in savings. When multiplied across the 140,000 ships entering the port every year, this means that the port will be able to dock more ships while shipping companies reduce costs each time they dock at the Port of Rotterdam.
- Digital dolphins, smart quay walls, and sensor-equipped buoys will provide insights on the condition and utilization of a berthing terminal and the surrounding water and weather conditions, enabling port operators to identify the optimal time for ships to dock, and where and when they can do so.
- As part of a multi-partner initiative, IBM cognitive IoT technology is being infused into a production process that uses a robotic welding arm to apply high-quality metal layer by layer to create ship components such as propellers, on-demand and faster than ever before—from six to eight weeks to just 200 hours.

## UPS Ups Cross-Border Investment

To support commercial and residential commerce in the growing North America Borderplex, UPS will develop a new package operations center there. The strategic investment serves a manufacturing region that stretches across Texas, New Mexico, and Ciudad Juarez, Chihuahua, Mexico. The North American Borderplex area is home to 2.5 million people and one of the world’s largest bilingual workforces. The UPS facility will add more than 153,000 square feet of new processing capacity and is expected to begin operating in late 2018.

UPS’s \$41-million project in El Paso is part of a multi-year investment plan to grow the company’s smart global logistics network, which helps connect businesses and economies through cross-border trade. Since early 2016, UPS has announced plans for 16 new and expanded U.S. facilities that will create more than 8,650 full- and part-time positions.

Manufacturing industries including automotive, electronics, appliances, and machinery producers will benefit from enhanced delivery speed and accuracy from the new El Paso center’s advanced package scanning and sortation equipment. The advanced technology also features increased flexibility to more efficiently route packages through UPS’s smart global logistics network.

The new facility will also support the UPS Trade Direct Cross Border service, an integrated solution that simplifies the cross-border shipping process by allowing shipments to bypass distribution centers, shipping directly to retail stores or end consumers across the Mexico/U.S./Canada borders.



## H&M TRIES ON SUPPLY CHAIN IMPROVEMENTS

The world’s second-largest fashion company, Sweden’s Hennes & Mauritz (H&M), says it will increase supply chain investments and continue cost control measures to address slow growth in 2017, and keep pace with e-commerce rivals.

After a supply chain reorganization in 2016, H&M’s new focus includes investing in data analytics and intelligence to enhance retail assortment planning and sales. It will also invest in technology to expand cloud computing, RFID, and 3-D printing.

The retailer’s supply chain processes had remained the same while the world changed, notes H&M Chief Executive Karl-Johan Persson, adding that H&M will “definitely” move some production closer to end markets while keeping an eye on profitability. “The company will also seek more flexibility with suppliers, so it needs to lower inventories and boost spending to make the supply chain more flexible,” he says.

# Airline Confidence Stays High

## Recent and Expected Change in Cargo Traffic Volumes

% of Respondents

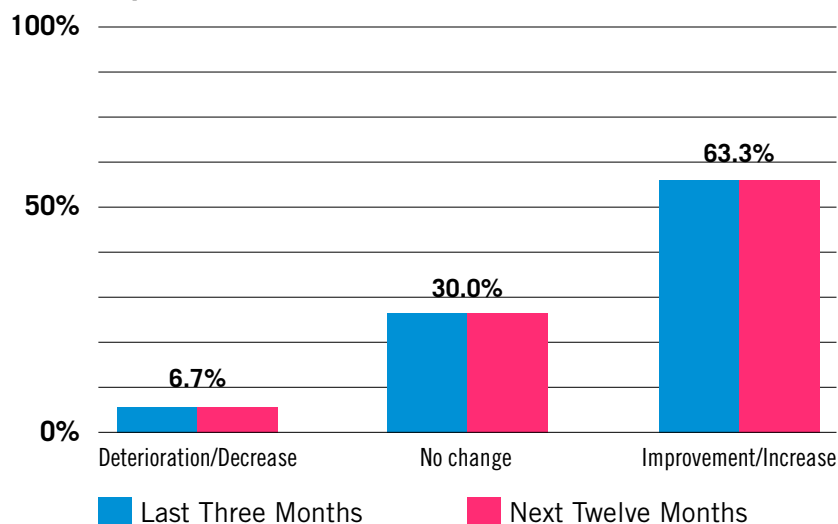

SOURCE: IATA Economics Briefing, January 2018 Survey

The 63 percent of airline CFOs and heads of cargo respondents to IANA's survey reporting a year-on-year rise in demand over the previous three months was the highest share for this measure since Q2 2011.

Meanwhile, the proportion who reported a decline (7 percent) was the lowest in more than seven years.

This combination lifted the backward-looking weighted-average score to its highest level since the post-crisis demand rebound in 2010/2011.

**AIRLINE MANAGEMENT CONFIDENCE** remains high, despite concerns about higher fuel costs, and an expectation that profits will fall from 2017, according to the International Air Transport Association's (IATA) latest Airline Business Confidence Index.

Among the index highlights:

- Nearly 75 percent of airline CFOs and heads of cargo indicate an improvement in year-on-year profitability in Q4 2017 compared with the same period in 2016.
- The majority (56 percent) expect profitability levels to improve further over the coming 12 months. Robust demand growth on both the passenger and freight sides of the business support this positive outlook.
- 38 percent of respondents report an increase in input costs in Q4 2017 compared to the same period one year ago, with many singling out the impact of higher fuel prices. The upward trend in oil prices is expected to continue to impact airline costs in the year ahead. That said, partly as a result of the strength of the economic backdrop and current demand/supply balances, respondents appear confident about the outlook for freight yields over the year ahead; both forward-looking weighted-averages scores are currently above the 50-mark.
- With 41 percent reporting no change in input costs, the backward-looking weighted-average score came in above the 50-mark for just the third time in 19 quarters. "Looking ahead, rising fuel prices were cited as a key driver for the 34 percent of respondents who reported that they expect input costs to increase over the coming 12 months," according to the index.
- 22 percent expect input costs to decrease over the year ahead, driven in part by internal productivity gains and cost reduction programs, including the adoption of more fuel-efficient aircraft.
- Looking ahead, 80 percent of respondents expect yields to remain steady or to increase over the year ahead (*see chart*). The forward-looking weighted-average score has trended upwards since reaching a trough in Q1 2016.
- 39 percent of survey respondents report an increase in employment levels in Q4 2017 relative to the same period in 2016—slightly below the outcome in the previous survey.
- 19 percent of respondents report a fall in employment levels in Q4, down from 21 percent last quarter, although an increase in the proportion of responses indicating no change means that the backward-looking weighted-average score fell slightly from the previous survey.
- 37 percent of respondents report that they expect to increase employment levels over the year ahead, with many citing rising demand. With a similar proportion indicating that they will keep levels unchanged, the forward-looking weighted-average score remained steady from the October 2017 survey, firmly in expansionary territory.



# LOGISTICS knowledgebase®

Jennifer Benson, VP of Customer Success, 3PL Central  
310-341-3317 • jbenenson@3plcentral.com

## Want to Run a More Successful 3PL? Learn from the Best.

**T**oday's third-party logistics and warehouse community is accomplishing spectacular things in our rapidly changing environment. From increasing productivity, to growing their customer base, to raking in higher profits, warehouses are thriving in today's marketplace.

Like any 3PL owner, you're always looking for ways to improve your own results, as well. At 3PL Central, we have always found that the best way to replicate the success of industry leaders is to study their tactics and strategies—and then implement them in your own operations.

We are happy to report that we have many examples of highly successful 3PLs among our own customers. This has enabled us to identify five crucial best practices our most successful 3PLs are using to help drive accuracy and increase efficiencies—all while simplifying their processes.

These best practices have formed the foundation of their remarkable success. But most of all, 3PL Central found that these 3PLs believe, as we do, that great businesses are built on "people, process and technology." As such, each of these aspects are equally important in their efforts to become a more productive and customer-driven warehouse.

Warehouses who use this philosophy to create disciplined, rigorous strategies were able to achieve superior results. These plans are largely based on these 3PLs' own self-knowledge. And of all the things they know about themselves, we found these to be the most important:

### 1. Know who you are—and what type of customers you serve.

A clear knowledge of what you do—and do better than the competition—can help reduce the blind spots in your business and provide a clear path when looking to grow. The best 3PL warehouses know exactly what they do best, which enables them to target a specific customer type and provide superior service.

This laser focus allows 3PLs to be incredibly efficient and extremely profitable—while helping them to retain their most lucrative clients for years on end—without having to chase new clients outside of their areas of expertise.

**2. Know you must be built to change—and change quickly.** Top-performing 3PLs don't simply react to changes in our industry. Instead, they anticipate their arrival, spot trends as they are developing, and are already up and running in the changed

environment before other warehouses can even begin to respond.

This mind-set impacts everything from the staff they hire—to the technology they purchase. This mentality helps ensure they can capitalize on fast-moving, but extremely lucrative, opportunities as they arise.

**3. Know how to retain your current warehouse staff.** The disastrous shortage of qualified warehouse workers has been an industry-wide crisis for years. Yet the best warehouses have no trouble attracting and retaining the top talent needed to succeed.

Warehouses who invest into their staff by creating a positive working environment and providing on-the-job training—while maintaining the highest ethical standards—can expect to have a happy and productive group of employees. In return, many warehouses find that employees reward them with hard work, innovative thinking and long-term loyalty.

### 4. Know the importance of monitoring your warehouse data.

Like many of you, top-tier 3PLs know we all operate in an increasingly digital world. But rather than seeing the terabytes of data produced as a mere by-product of daily work, top 3PLs realize it is a potential goldmine for new services, greater efficiency and happier customers.

Analyzing warehouse data can enable 3PLs to forecast everything from their staffing needs, to process efficiencies, costs-per-service and more. It can even show which customers a warehouse should hang on to—and which ones they may choose to replace.

### 5. Know when to upgrade your technology and when to hold off.

In addition to monitoring data, top-tier 3PLs create rigorous internal processes that track business expenses, operational efficiencies, and costs to service their customers. In addition, these 3PLs always keep abreast of their customers' future plans.

This information helps ensure that every technological purchase is made at the right time—for the right reasons—and provides the return on investment they demand.

At 3PL Central, we're dedicated to helping all 3PLs capitalize on the incredible opportunities our industry now offers. We hope this article provides your 3PL with the insights it needs to become an even more successful, efficient and lucrative operation.





Find **Shelving** 🔍

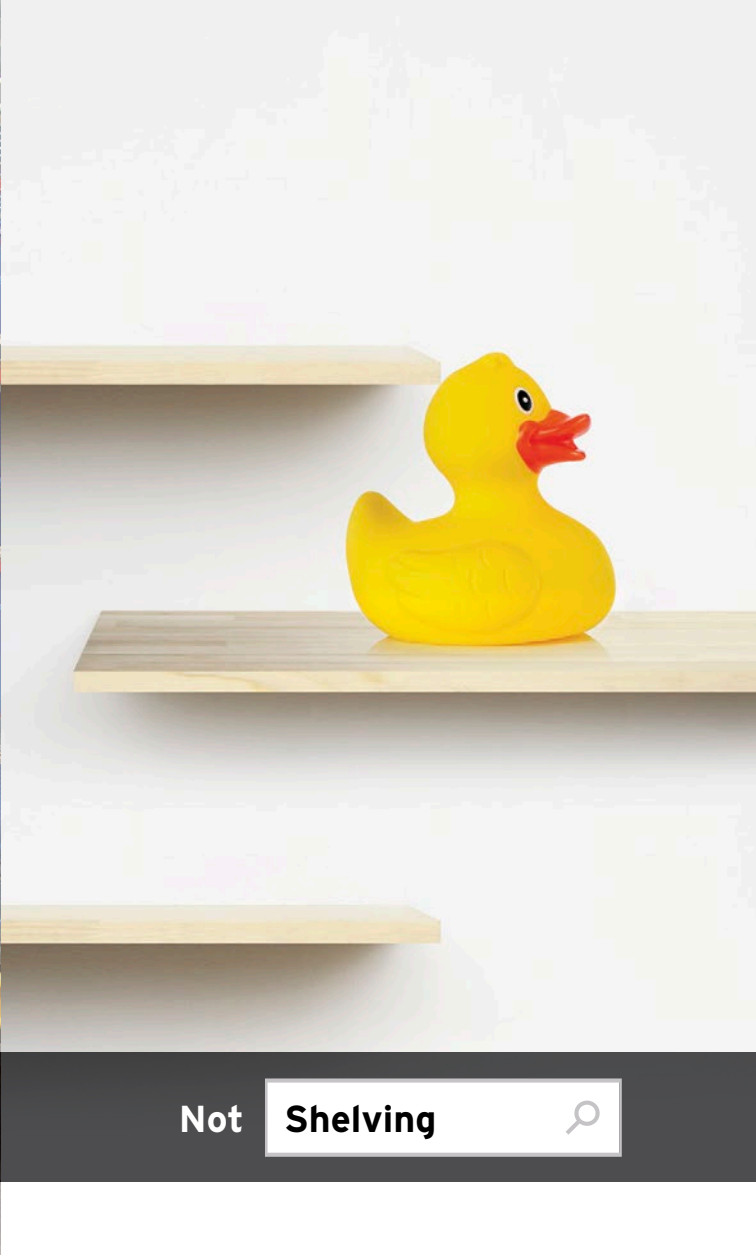

Not **Shelving** 🔍

THOMAS is a trademark of Thomas Publishing Company LLC

Search industriously  
at [Thomasnet.com](https://www.thomasnet.com)®.



Got 3PL challenges?

Get free expert solutions at [inboundlogistics.com/3pl](https://inboundlogistics.com/3pl)



## VIEWPOINT

BY TIMOTHY G. TAYLOR

Consultant, ShippersEdgeTMS.com  
timothy.taylor@shippersedge.com | 952-777-4421

# How to Contain Rising Truckload Prices

**Y**ou've no doubt seen your truckload shipping costs skyrocket. If you're a niche user—flatbed or refrigerated—you're probably reeling at the price increases. Your brokers tell you prices will moderate; they're wrong. Let's explore strategies to help you contain increasing prices.

Let's talk about why these prices are here to stay. First and foremost, the driver shortage persists. Truck drivers have taken a beating over the past eight years. They work for about 40 cents per mile and pull in approximately \$45,000 per year for working 70 hours a week. They also have to eat and sleep out on the road and sometimes in dangerous places. It is not an easy life, and it's a job most millennials won't do.

Drivers are jumping for higher pay. Most people think 60 cents per mile is the number to attract new entrants into the market. That's a built-in 10-percent increase to get the driver.

### A Tidy Increase

Diesel, too, has increased to nearly \$3 per gallon, and most trucks still average around six miles to the gallon, so there is your five-percent increase. Factor in the shortage of equipment, and trucking firms are baking in another five percent. It all makes for a tidy 20-plus-percent increase.

So how do you position yourself to reduce the impact of these current

conditions? Several strategies can help you, both in the purchasing and operational areas.

**1. Be open nights, especially if you're in a big city.** Why? Congestion. Drivers love to run nights, and they hate rush-hour traffic. Buttoning up a truck at 4 p.m. gives the driver a nightmare getting out of Dodge. You might not be able to do it, but you should consider it as a money-making and equipment-gathering strategy.

**2. Provide driver parking.** There simply are not enough parking spots for trucks. That sometimes leads to safety issues especially in inner cities. Even some suburban areas are fraught with danger for drivers. If you're known as a driver-friendly facility, the word will get out. Driver friendly also includes a comfortable waiting area, use of bathrooms, and Wi-Fi that works all the way out in the yard.

**3. Be quick about loading.** Drivers can run 11 hours on the road, then they must take a 30-minute break, and they have to pre-trip inspect their equipment. That leaves about two additional hours

in their 14-hour duty cycle. Think about that: 14 hours on duty. They should definitely earn more than \$45,000 per year.

### Avoid the Spot Market

Some shippers broadcast a list of loads to multiple providers, both asset-based and non-asset-based. Don't do it; you are sabotaging yourself. Why? Brokers are bidding against each other for the truck and spiking the spot market.

Find one broker or one broker for a lane and stick with them. The load-to-truck ratios are sometimes 30 to one. That, as you know, is not tenable. Stop sabotaging yourself.

Be a quick payer. Trucking firms have to front everything, including higher diesel and now higher driver pay. They can't finance you. They won't finance you.

Some trucking firms go to factoring companies charging rates that would make a shylock blush. That only adds to your cost. These factoring rates can exceed five percent; you'll pay it one way or another. If you're the shipper who pays upon presentation, you'll have a loyal following of truckers.

In short, skyrocketing truckload shipping costs shouldn't steer your supply chain off course. Pursue driver-friendly practices, avoid the spot market, and pay promptly to secure capacity and handle rising rates. ■



Find

Metal

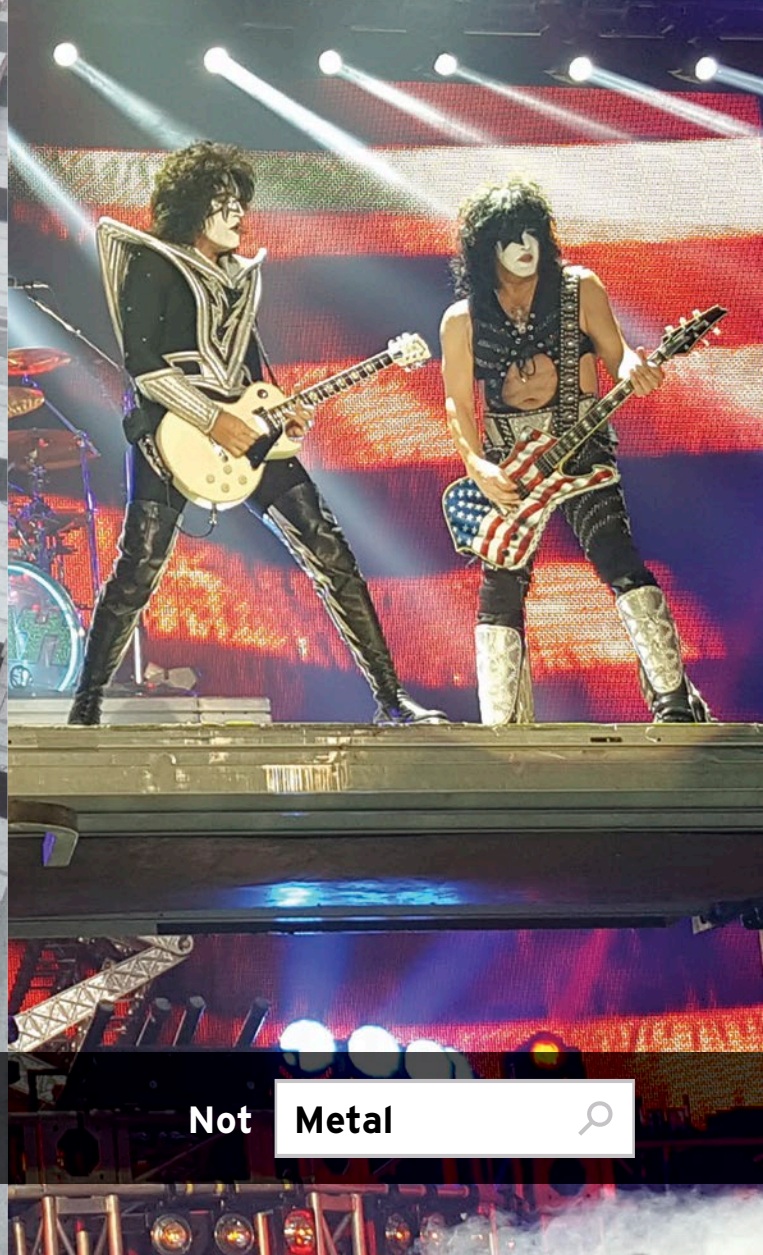

Not

Metal



THOMAS is a trademark of Thomas Publishing Company LLC

Search industriously  
at [Thomasnet.com](https://www.thomasnet.com)®.

 **THOMAS**™  
For Industry.

Got 3PL challenges?

Get free expert solutions at [inboundlogistics.com/3pl](https://inboundlogistics.com/3pl)



## TRADE COMPLIANCE STRATEGIST

BY GABRIELLE GRIFFITH

Director, BPE Global  
ggriffith@bpeglobal.com | 650-245-1661

# Yes, NAFTA Affects Your Industry Too

**T**he symbiotic relationship between trade compliance and supply chain is the cornerstone of a shipper's competitive advantage. You know this well, but you may be unfamiliar with how NAFTA affects your entire supply chain.

Service providers who stay current on the global trade landscape are assets to their clients. I know, I used to be that client. As much as I would educate myself on the newest changes in trade compliance, being able to leverage my service providers for added input greatly contributed to our supply chain's strength.

Companies can't afford to have non-compliance issues slow the movement of goods or stop shipments to certain areas of the world. They need informed and strategic partners at every level of their supply chain.

Though a company might not leverage duty-free treatment under the North American Free Trade Agreement, there are some additional elements to consider that might impact your supply chain.

NAFTA went into effect in 1994 and provides tariff-free treatment to goods traded between Canada, Mexico, and the United States. In May 2017, President Trump notified Congress of his intent to renegotiate this agreement. February 2018 marks the seventh round of talks, which

to date have had minimal progress on renegotiation.

### What is Impacted?

Not only are products eligible for duty-free treatment at stake under NAFTA renegotiation, but other considerations could affect your company, such as:

- **Procurement:** Possible limitation of U.S. companies' access to Mexico and Canada opportunities.

- **Content requirement:** Proposal to raise the mandated amount of U.S. content within certain sectors.

- **De minimis:** Recommendation to raise the de minimis (minimum dollar value of qualifying goods for which formal customs procedures are not required and duties or fees are not collected) threshold in Canada and Mexico to match U.S. de minimis (\$800 USD)

- **E-2 Investor Visa companies:** The E-2 visa allows individuals to enter and work inside the United States based on an investment they will be controlling while inside the country.

NAFTA renegotiation impacts a wide range of entities, including:

- Importers currently benefitting from the NAFTA program.

- Any business with brick-and-mortar stores in Canada or Mexico.

- Businesses driven by government procurement.

- Businesses founded by, or doing business with, an E-2 visa holder.

### Current Renewal Status

Canada, Mexico, and the United States agree they intend to modernize the agreement. Mexico and Canada oppose the U.S. intention to increase U.S. content percentage in the automotive sector.

As of Jan. 31, 2017, six of the seven negotiation rounds had taken place and will continue through the first quarter of 2018. To date, the three parties recognize the importance of negotiations and agree longer rounds of talks might be necessary, especially with the Mexico elections in July 2018.

Though recent negotiations seem optimistic, the risk of NAFTA withdrawal is real and cannot be ignored. Aside from knowing their numbers if losing duty-saving opportunities, companies need to stay informed to ensure their supply chains retain their competitive advantage. ■



Find

**Tubing**



Not

**Tubing**



THOMAS is a trademark of Thomas Publishing Company LLC

Search industriously  
at [Thomasnet.com](https://www.thomasnet.com)®.

 **THOMAS**™  
For Industry.

Got 3PL challenges?

Get free expert solutions at [inboundlogistics.com/3pl](https://inboundlogistics.com/3pl)



**BY MATT MARKHAM**

Director, Center of Innovation for Logistics  
Georgia Department of Economic Development  
mmarkham@georgia.org | 404-962-4134

# How Georgia Designed an Innovative Logistics Landscape

Industry groups need to come together and support a sustainable logistics ecosystem. State organizations play a critical role in achieving this goal, as they are often the hub that facilitates seamless interactions between businesses, government agencies, industry groups, and educational institutions.

Georgia, for example, supports a robust industry that's successful on a national and global scale. The Center of Innovation for Logistics provides a macro-level view of the state's logistics ecosystem, connecting businesses with challenges to the people and organizations that can solve them.

While Georgia boasts the world's most traveled airport and the fastest growing container seaport in the country, there's a lot more to it. Here's insight behind the state's success, and how the rest of the industry can learn to build an innovative logistics landscape.

## A Robust Education System

As the logistics sector grows, the sustainability of that success depends on the quality of the state's workforce. To ensure workforce needs are met, it's critical to foster a robust education system.

For example, Georgia Tech's Supply Chain and Logistics Institute serves as a converging point between the public and private sectors, bringing new technology and ways of doing business to

logistics companies throughout the state.

Georgia also supports workforce needs through programs such as the High Demand Career Initiative, which responded to an industry truck driver shortage by enabling state residents to attend commercial truck driving programs through local colleges at no cost.

## Infrastructure Investments

Another key driver of logistics success at the state level is investment in a complete transportation infrastructure. Rather than focusing on developing one method of transportation, states with a robust logistics sector commit to supporting multiple channels—from seaports and inland ports to railways and airports. These states recognize that each mode's success depends on the success of the other modes.

While the construction of roadways and facilities is an imperative baseline, technology is equally important to supporting a broad infrastructure.

The combination of Georgia's location and comprehensive infrastructure

assets enables the state to sustain a transportation ecosystem that allows companies to reach 80 percent of the U.S. market in less than two days.

## Industry Awareness

A strong network of logistics assets means nothing if companies aren't aware of how that network can benefit their business. This is where state organizations can shine by connecting businesses to the tools, training, and organizations that will help them.

It's also important to provide businesses and industry groups with large-scale opportunities to discuss how the transportation landscape can move forward.

To do this, the state hosts the annual Georgia Logistics Summit, which brings together all facets of the industry. It's an effective way to educate businesses on industry innovations, as well as inform them of the organizations and groups available to connect them.

The logistics sector is all about connecting businesses to their partners and enabling collaboration between every party involved in the transportation ecosystem—from the private and public sectors to educational institutions and industry associations. Georgia found success using this model; now the challenge is for other states to take note. ■

# Shippers Warehouse is now The Shippers Group



Since 1901, we've been in forward motion towards being an industry leader in third party logistics with a focus on our people, our processes and the technology we employ to enhance the overall customer experience.

Our service offering has grown from just warehousing to include transportation, packaging and e-commerce solutions, and it is time for a more relevant name.

- **Full Range of Services**

- › Public and Contract Warehousing
- › Contract Packaging
- › Pick-n-Pack and E-Commerce Fulfillment
- › Transportation Services
- › 4 PL Integration

- **Warehouse Locations in TX, GA, CA IL, VA**

We offer 4.8 million square feet of warehouse space in 11 locations.

- **Air Conditioned & Ambient Temperature Facilities**

Conditioned space is closely monitored to ensure product quality of food, pharma and nutraceutical products.

- **Green Citizen: Sustainable CPG Member**

Inbound Logistics G75: The 75 leading companies that go above and beyond to ensure their global supply chains are sustainable and that their operations are socially and environmentally friendly.

- **BRC Superior**

British Retail Consortium is a global standard for food safety, and we have a AA (superior) rating.

- **AIB Superior**

Our food grade facilities have achieved superior AIB Sanitation Ratings for over 20 years, with a most recent score of 990 out of 1000.



CORPORATE OFFICE 8901 Forney Road | Dallas, TX 75227  
SALES 214-275-1060

To learn more about what  
The Shippers Group can do for you,  
call 214-275-1060 or visit us online.

[SHIPPERSWAREHOUSE.com](https://www.shipperswarehouse.com)

Got 3PL challenges?

Get free expert solutions at [inboundlogistics.com/3pl](https://inboundlogistics.com/3pl)



# Core Competencies Every Supply Chain Manager Needs

## CRITICAL SKILLS

SKILLSET	OUTSTANDING	EXCELLENT	GOOD	FAIR	POOR
STRATEGIC ORIENTATION	✓				
GLOBAL PERSPECTIVE		✓	✓		
LEADERSHIP		✓			✓
DELEGATION				✓	
COMMUNICATION					
PROBLEM SOLVING					
ADAPTABILITY					





**Acquire these skills and competencies to build success in your supply chain—and your career.**

**By Tamara Chapman**



**F**or supply chain professionals eager to negotiate the career ladder, one thing is certain: Yesterday's resume already needs an update.

That's because the core competencies essential for optimized performance have changed considerably, not just as a result of advancing technology, tighter budgets, and rising consumer expectations, but also due to shifting demographics and global realities.

With an ever-evolving economic landscape in mind, *Inbound Logistics* asked supply chain education and professional development experts (*see sidebar, page 40*) to identify the competencies that every enterprising professional's resume should reflect.

The new competencies apply to supply chain professionals working in the for-profit and public arenas, in companies of every size and in government agencies at the local and national levels, notes Nora Neibergall, senior vice president for certification and standards at the Institute for Supply Management, a not-for-profit professional supply management organization. What's more, they supplement

the core competencies of yesterday—among them, negotiating skills, cost-price analysis, and sourcing.

“These skills are all still very important,” Neibergall notes, “but a whole layer of complexity has been added as we move to a truly global marketplace.”

Companies expecting to retain or achieve an advantage in this “competitive arms race for talent” would do well to develop these competencies within their organizations and to seek job candidates already versed in them, agrees Mark McEntire, senior vice president of operations at Transplace, a third-party logistics provider based in Frisco, Texas.

With the supply chain deemed increasingly important within an organization’s operations, here are the top skills career development experts consider essential:

## 1 STRATEGIC ORIENTATION

Successful supply chain professionals have always seen opportunities for saving money within their operations. But today, they need to be “looking at the supply chain as a competitive lever that you can pull,” says Kate Reigel, who directs a new master’s of science program in supply chain management at the University of Minnesota’s Carlson School of Management.

That means thinking with a C-suite perspective. After all, Reigel says, dramatic changes—and opportunities—in the supply chain have come to the attention of those in the boardroom, where chief officers of everything from marketing to finance are finally talking supply chain management.

What’s more, they have invited “chief supply chain officers” into the circle. “When I was in business school, the chief supply chain officer role didn’t exist,” Reigel says. “You had a CEO, a CFO, and a CIO,” but the chief designations stopped there.

“Historically, the supply chain’s function was often to just get the goods there when they tell you to,” she adds. “But now, the supply chain can be used to deliver value to organizations.”

C-suite thinking requires what

## Meet Our Career Coaches

To identify the skills that all enterprising supply chain professionals should include in their resumes, *Inbound Logistics* turned to three supply chain education and career development experts.



**KATE REIGEL** directs a new master’s of science program in supply chain management at the University of Minnesota’s Carlson School of Management. The fledgling program, now in its second year, was designed around a handful of “key principles” for supply chain leadership. Reigel oversees the program, and teaches its experiential capstone course.



**MARK McENTIRE** is senior vice president of operations at third-party logistics provider Transplace. As an executive focused on keeping Transplace competitive, he champions a professional development initiative that recruits the best and brightest from top university supply chain programs, and then hones their skills and cultivates their talents.



**NORA NEIBERGALL** is senior vice president for certification and standards at the Institute for Supply Management. ISM is in the process of updating its Certified Professional in Supply Management® program, open to aspiring professionals from around the world.

Reigel calls “the knowledge and understanding of an end-to-end perspective.” Sometimes that understanding may be tapped to restrain ambitious plans; other times it might be harnessed to accelerate them. For example, a full understanding of the chain might mean the difference between scheduling a simultaneous launch or a staggered launch of new outlets in new markets. By the same token, a deep knowledge of procurement options and strategies can shape high-level decisions about product design.

Finally, a strategic orientation means understanding how even matter-of-fact decisions have high-level impact—how, say, the choice of a supplier might have ramifications for the brand or a research/design/development/delivery timeline.

## 2 A GLOBAL PERSPECTIVE

At the micro level, “buy local” is increasingly a consumer mantra. But at the macro level, everything is

global—and has been for some time.

That’s why a global perspective is a must, no matter the size and reach of the company. “We all source globally now, and it’s impossible not to understand that your supply chain is heavily influenced by international factors,” Neibergall says.

A global perspective includes knowledge about importing, exporting, trade agreements, and customs regulations, of course. But it goes beyond that to include what academics call “cultural competencies.”

“The ability to work with teams from around the world with different perspectives is critical,” Neibergall explains. “It becomes very important to understanding where your suppliers are, and where their suppliers are. There’s a whole element of risk management and quickly being able to work with people on the other side of the supply chain.”

Cultivating cultural competency often requires more than background research. “It’s not always a skill you can get from classroom instruction,”



# STUDY THE LATEST SUPPLY CHAIN CONCEPTS

## Earn the Best Supply Chain Credentials

There is a growing demand for supply chain and logistics experts. The importance of issues like disaster recovery have been highlighted by recent events, while new topics such as big data and blockchain technology now demand attention.

Who will fill the demand?  
**SPARTANS WILL.**



Michigan State University's supply chain/logistics graduate and undergraduate degrees are ranked #1 by U.S. News & World Report. Certificate programs offer highly focused specialties, including:

- **Supply Chain Management and Logistics**
- Global Supply Chain Management
- Procurement Management
- Supply Chain Management and Operations
- Integrated Supply Chain Management

Visit [msuonline.com/scmlogistics](https://msuonline.com/scmlogistics) to learn more.



“The big data provided by blockchain technology enhances the safety and efficiency of the food supply chain by allowing us to see an integrated flow for any item, regardless of where it came from. We can go back to the start or right to the end. This increases safety by keeping the entire supply chain visible; we're able to track products through every step of the process. It also boosts efficiency by helping us follow products all the way to the consumer, so we know what people are actually buying.”

*Dr. David J. Closs, MBA, PhD  
John H. McConnell Chaired Professor of Business Administration  
in the Department of Supply Chain Management at Michigan State University*



To build collaboration with staff and external partners, every supply chain professional needs the ability to communicate clearly.

Neibergall says. “You might have to get it through a mentoring process, with somebody who has experience within the region, culture, or country you need to work with. That’s where building your network is critical.”

### 3 LEADERSHIP FROM ALL THE COMPASS POINTS

No matter a supply chain professional’s position in the company hierarchy, leadership opportunities exist. Seizing those opportunities is essential, both for individual career mobility and for the company’s bottom line.

“Not everyone is going to be chief purchasing officer,” Neibergall says. “We joke that millennials think they’re all going to be the chief procurement officer, but realistically there are not that many CPOs in the world.”

“But there are abundant opportunities for leadership,” she notes. “Even an entry-level position presents opportunities to lead from the bottom or the middle. You are engaged in teams and in work groups, and you deal with suppliers. You have opportunities to lead all the time, and you have to recognize and maximize them.”

Today’s challenges demand what Reigel calls “leading beyond boundaries”—which means leading others outside the immediate team and perhaps even outside the employing company.

“The supply chain requires various partnerships with customers and suppliers,” she says. These relationships require leadership, whether the task at hand involves approaching a partner with a new idea or seeking a solution to an unfolding challenge.

### 4 ANALYTICS KNOW-HOW FOR DECISION-MAKING

“The supply chain generates enormous volumes of data,” Reigel explains. “Where’s the inventory? How is it being shipped? Is it being delivered on time? Is it being returned? How do you amass all these pieces of data in a way to help make strong business decisions?”

Knowing which data to enlist, and then using that information effectively, can be challenging. As McEntire sees it, supply chain professionals need to learn how to find stories within the sea of data. Once that’s done, he says, they need to figure out how to relay the stories to those charged with developing strategy and implementing plans.

That’s where effective data visualization comes in. It can make the difference between “aha” recognition of a path forward and a vague sense that the numbers reflect a compass point, McEntire explains.

That said, McEntire believes that data goes to waste if it isn’t accompanied by “a bias toward action.” Data

can be overwhelming, and it’s easy to postpone a decision under the guise of needing more information or overthinking the data on hand.

“It is so easy to just kick the can down the road,” he says. Easy though it may be, delayed decision-making can be costly and demoralizing to staff. Let the data point you in the right direction, but learn to “be comfortable making decisions when you don’t have all the information at your hands,” McEntire says.

Neibergall agrees. “We are truly a data-driven society, and businesses expect you to utilize as much of the resources as you have available and try to improve decisions,” she says. “But you can’t overanalyze things. It’s not just understanding how to get the data and how to use it, it’s also being able to synthesize the data, make decisions, and be able to act on them.”

### 5 COMMUNICATION SKILLS

A bias toward action can lead to missteps if the plan isn’t communicated well. That’s why every supply chain professional needs to anticipate what people need to know, share that information at the appropriate time, and explain it without ambiguity. No decision will be implemented efficiently or effectively if it isn’t communicated well.

“Communication skills can’t be

UNIVERSITY *of* WASHINGTON

# GAIN A STRATEGIC ADVANTAGE

---

The **Master of Supply Chain Transportation & Logistics** program gives you the technical skills and big-picture perspective needed to separate yourself from the pack. Learn from world-class faculty and industry leaders through a work-compatible online curriculum at the University of Washington's College of Engineering, ranked 15th in public engineering graduate schools by *U.S. News & World Report*.

**SUPPLY-CHAIN-TRANSPORTATION.UW.EDU**



Got 3PL challenges?

Get free expert solutions at [inboundlogistics.com/3pl](https://inboundlogistics.com/3pl)

overemphasized,” Niebergall notes. They are essential to building collaboration and, just as important, “to facilitating difficult discussions.”

Supply chain leaders need to learn how to communicate up—to synthesize data and arguments so the leadership team can act effectively. Niebergall calls this “being able to translate what’s happening in supply management in a way that the CFO or CEO will understand and appreciate.”

At the same time, McEntire adds, supply managers need to be able to communicate with their direct reports. As any good communications/management textbook will argue, managers need to be able to provide necessary context and insight into strategies, as well as understand how language can be used to motivate or demotivate.

Supply chain managers also need “customer-facing” communication skills, McEntire says. They need to speak a language conducive to building partnerships—a language that communicates a mutually beneficial vision.

## 6 A RESPONSIBILITY ETHIC

Environmental responsibility is integral to the supply chain. After all, the supply chain is where packaging is reduced, transportation options reconsidered, and the carbon footprint contained.

But increasingly, responsibility means more than an obligation to use resources wisely and protect the environment. “There’s also a people piece,” Reigel explains.

Many companies found out just how important the people piece is in 2012 when a fire broke out in a Bangladesh fashion factory. With 115 workers left dead, attention turned to the conditions at the factory and to the clothing brands that benefited financially from cheap labor toiling in an unsafe environment.

That’s the kind of attention no company wants. It illustrated “that it’s now time to take ownership of your customer’s customer and your supplier’s supplier,” Reigel says.

Niebergall agrees. Ensuring that your

suppliers behave responsibly is part of effective risk mitigation and brand preservation. That means recognizing the conditions that signal slavery and bonded labor in the supply chain or health-endangering practices that might lead to a product liability suit.

“It’s being able to understand how to protect against that, how to remedy it, and ensure that you have a good supply chain,” she says. “It’s not only about brand protection, but also about

potential financial losses and litigation. As a supply manager, one of your roles is to keep your company out of trouble.”

Niebergall takes the responsibility walk one step further. In addition to protecting the brand through people-friendly practices, she believes responsibility entails inclusion, paying attention to diversity issues, and “ensuring that your work force and leadership team reflect the communities that you serve, your customer base.” ✓

## Check Your Soft Skills

In today’s global marketplace, a number of competencies, skills, and attributes are essential, while some are simply desirable. They probably won’t appear in the job description, but they’ll make the job easier and lead to better results. These include:

✓ **Language skills.** Anyone whose firm is directly doing business overseas should study languages, recommends Nora Niebergall, senior vice president for certification and standards at the Institute for Supply Management.

People charting their professional paths “would be super marketable with second or third language skills,” she says. “That’s certainly something younger people should think about when building their portfolio skills.”

✓ **Flexible thinking.** “This is tied to strategic thinking, but it’s being agile and adept as you face new challenges,” explains Kate Reigel, director of the master’s of science program in supply chain management at the University of Minnesota’s Carlson School of Management.

It means thinking beyond customary boundaries to solve problems. It’s “how you’re thinking as opposed to what you’re thinking about,” she says. People can cultivate flexible thinking, in part, by examining how professionals from other divisions and fields address challenges.

✓ **A dose of humility.** Supply chain professionals don’t need to know everything, but it’s essential that they know that they don’t know everything.

A good dose of humility helps professionals overcome hurdles and ask questions—even questions that might make them look uninformed or point to a serious knowledge gap. “A lot of people get paralyzed because they are afraid to ask for help,” says Mark McEntire, senior vice president of operations at Transplace. In turn, that paralysis can tank a project and a career.

✓ **Insatiable curiosity.** When considering young professionals for Transplace’s professional development opportunities, McEntire is more likely to select someone who asks lots of how and why questions.

That curiosity, when paired with a high-octane work ethic, can help today’s supply chain professionals stay ready for whatever the future brings. After all, McEntire says, “They’re going to see a lot of transformation and change in their career.”

# Advance your logistics career

Earn the Certified in Logistics, Transportation and Distribution (CLTD)

The CLTD credential is designed to help you and your organization meet today's global supply chain challenges.

- Master the essential knowledge needed for logistics, transportation and distribution
- Remain current with global logistics trends and developments
- Reduce costs and impact your organization's bottom line



Test your logistics knowledge. Take a short five question quiz at [apics.org/cltd-take5](https://apics.org/cltd-take5).



Got 3PL challenges?

Get free expert solutions at [inboundlogistics.com/3pl](https://inboundlogistics.com/3pl)



## Finding Solutions *through* Industrial Distribution & Logistics

On campus and online, East Carolina University prepares professionals with the expertise to manage complex supply chains and global logistics. We offer:

- BS in Industrial Distribution and Logistics
- BS in Industrial Technology  
*Two year accelerated program for AAS degree community college graduates*
- MS in Technology Systems  
*Concentration in Distribution and Logistics*

Visit [www.ecu.edu/idis](http://www.ecu.edu/idis) today for more information.

**SAP  
University  
Alliances**

An equal opportunity/affirmative action university, which accommodates the needs of individuals with disabilities. C.S. 16-1508

## JobsInLogistics.com

The Leading Source for Targeted Logistics Candidates  
Call (877) 562-7678



Supply Chain • Transportation • Freight Forwarding  
Warehousing • Distribution • Purchasing & More

## 3PL Staffing Firm

Specializing in direct and contract hiring including:

- CEO's, COO's, CFO's, CIO's, CMO's, CLO's
- Vice Presidents / Directors
- Sales Managers
- Directors Of Business Development
- Solutions Engineers
- TMS/WMS/LMS Systems Implementation Managers
- Carrier Sourcing Managers
- Freight Brokerage / Branch Managers
- Facility Managers
- Pricing Managers
- IT Managers
- Trade Compliance Managers



Search Resources Inc.

*"Building world class supply chain organizations one individual at a time."*

All fees company paid.

847-382-3877

Fax: 847-382-3878

[www.srimatch.com](http://www.srimatch.com)



**TIA** offers real education solutions for busy professionals at every stage of your career.

**TIA** programs are practical, convenient, and designed by industry leaders to meet your career and business needs.

**New Brokers**

• **Certification**

• **Specialties**

**Industry Intelligence**



Discover the best options for you at  
[www.tianet.org/education](http://www.tianet.org/education)



## THE UNIVERSITY OF ST. FRANCIS IS FULL OF MOVERS AND SHAKERS

- USF offers bachelor's, master's, and certificate programs in logistics, transportation, and supply chain management.
- USF is located in Joliet, Illinois—an intermodal hotspot and home to North America's largest inland port.
- 100% online and on-campus course delivery options are available to accommodate every type of student.

### Questions?

Contact USF's College of Business & Health Administration  
[cobha@stfrancis.edu](mailto:cobha@stfrancis.edu)  
800-726-2600

Learn More  
[stfrancis.edu/movers](http://stfrancis.edu/movers)



COLLEGE OF BUSINESS  
& HEALTH ADMINISTRATION









## LOGISTICS & SUPPLY CHAIN EDUCATION RESOURCE GUIDE

SCHOOL NAME	URL & PHONE	Years offering logistics education	UNDERGRADUATE					GRADUATE				CONTINUING EDUCATION				VOCATIONAL/TRADE/TECHNICAL				COURSE LOCATIONS						
			Logistics or Supply Chain Major	Logistics or Supply Chain Minor	Logistics or Supply Chain Coursework	Logistics or Supply Chain Certification	Global Trade Coursework	Operations Management Coursework	Supply Chain Engineering Coursework	Master's Degree Program	MBA Concentration	MBA Coursework	Doctoral Program	Certificate Programs	Distance Learning Events	Executive Programs	Seminars & Short Courses	Warehouse Management	Inventory Management	Freight Management	Logistics Sales	Logistics Technology	Distance Learning	On Campus	On Site (Off Campus)	At Events (Off Campus)
HEC Montreal	hec.ca 514-340-6000	14	●	●		●	●		●	●	●	●			●	●	●						●			
Howard University	hucescm.com 202-806-1674	17	●				●		●	●													●			
Illinois Institute of Technology - School of Applied Technology	bit.ly/appliedtechEDU 312-567-3650	20		●	●	●	●	●	●			●					●	●	●	●	●	●	●	●		
Indiana State University - Scott College of Business	indstate.edu/ business/oscm 812-237-3365	13					●		●																	
Kansas State University	cba.k-state.edu 785-532-4350	30	●		●		●		●			●	●			●	●					●	●			
Kuhne Logistics University	the-klu.org/contact +49-403-28707160	8	●	●	●	●		●	●	●	●			●	●								●			
Lake Washington Institute of Technology	LWTECH.edu 425-739-8100	4	●																			●	●			
Lehigh University	lehigh.edu 610-758-3000	24	●	●	●	●	●	●	●	●		●	●	●	●							●	●	●	●	●
Lenoir Community College	lenoircc.edu 252-527-6223 Ext. 606	DNR			●	●						●										●				
Loyola University Chicago	luc.edu/scm 312-915-7654	25	●	●	●		●		●	●	●		●		●							●	●	●	●	●
Maine Maritime Academy	mainemaritime.edu 800-464-6565	26	●	●	●		●		●			●				●	●	●	●	●		●	●	●		
Marquette University	marquette.edu/ supplychain 800-222-6544	10	●	●	●		●		●	●													●			
Miami University	miamioh.edu 513-529-1809	20	●	●	●		●			●												●	●			
Michigan State University	supplychain. broad.msu.edu 517-353-6381	50	●						●	●	●	●	●	●	●							●	●	●		●
MIT Center for Transportation & Logistics	scm.mit.edu 617-253-5320	40									●	●	●	●	●							●	●	●		●





## LOGISTICS & SUPPLY CHAIN EDUCATION RESOURCE GUIDE

SCHOOL NAME	URL & PHONE	Years offering logistics education	UNDERGRADUATE						GRADUATE				CONTINUING EDUCATION				VOCATIONAL/TRADE/TECHNICAL					COURSE LOCATIONS				
			Logistics or Supply Chain Major	Logistics or Supply Chain Minor	Logistics or Supply Chain Coursework	Logistics or Supply Chain Certification	Global Trade Coursework	Operations Management Coursework	Supply Chain Engineering Coursework	Master's Degree Program	MBA Concentration	MBA Coursework	Doctoral Program	Certificate Programs	Distance Learning Events	Executive Programs	Seminars & Short Courses	Warehouse Management	Inventory Management	Freight Management	Logistics Sales	Logistics Technology	Distance Learning	On Campus	On Site (Off Campus)	At Events (Off Campus)
University of Southern California	bit.ly/USCSupplychain 213-740-0667	5			●	●	●	●	●	●			●	●	●	●		●				●	●	●		
University of St. Francis	bit.ly/stfrancisEDU 800-726-2600	7	●	●	●	●	●	●	●	●	●		●									●	●			
University of Tennessee	haslam.utk.edu 865-974-5061	80	●	●	●			●	●	●	●		●	●	●	●						●	●	●		
University of Texas at Austin	mcombs.utexas.edu 512-471-3322	DNR	●	●	●	●		●	●	●	●		●	●	●	●						●	●	●		
University of Texas at Austin - McCombs School of Business	mcombs.utexas.edu/Centers/SCMC 512-471-5921	16	●	●	●			●	●	●	●		●										●			
University of Washington, College of Engineering - Supply Chain Transportation & Logistics Masters	supply-chain-transportation.uw.edu 206-221-6407	5							●								●	●	●	●	●	●	●	●	●	
University of Wisconsin - Platteville Online	GoUWP.com 608-342-1468	7		●	●				●					●								●				
University of Wisconsin - Superior	uwsuper.edu/index.cfm 715-394-8101	20	●											●		●						●	●			●
Wayne State University	bit.ly/waynestateEDU 313-577-4525	25	●		●	●		●	●	●	●				●	●		●	●	●	●	●	●	●	●	●
Weber State University	bit.ly/weberEDU 801-626-7368	47	●	●	●		●	●		●	●		●										●			
Western Illinois University	wiu.edu/scm 309-298-1535	40	●	●	●		●	●		●	●		●	●			●	●	●	●		●	●			
Worcester Polytechnic Institute	wpi.edu/academics/business 801-626-7368	17			●			●	●				●									●	●			
World Food Logistics Organization Institute	wflo.org/institute 703-373-4300	54											●												●	●
Wright State University	bit.ly/wrightEDU 937-775-2895	36	●	●	●			●	●	●			●					●		●		●	●			

### Online Decision Support

Extended education listings are available online. Consult the Logistics and Supply Chain Education Decision Support Tool: [inboundlogistics.com/find-a-logistics-school](http://inboundlogistics.com/find-a-logistics-school)

Don't see your school or university here?

Submit your credentials to our Logistics and Supply Chain Education database: [bit.ly/edu\\_questionnaire](http://bit.ly/edu_questionnaire)

# CUSTOMIZABLE SUPPLY CHAINS

FIT TO A

T





**The challenges of tailoring a supply chain where no two items are the same, and everything is taken personally.**

**By Merrill Douglas**



**A**s merchants strive to deliver products to consumers faster and faster, some companies are working to cater to another yearning—the desire for products closely configured to our tastes and needs.

Customization can mean adding an embellishment of the customer's choice—a monogram, an engraving, or a hand-painted or screen-printed design. In other cases, the product is designed from the ground up to fit the customer's measurements or preferences.

The supply chain for customized products poses some special challenges. For instance, when every product is unique, inventory management requires different strategies. Also, merchants need to collect precise, accurate information about what each customer wants. They need to manage relationships with suppliers to meet unpredictable demand and maintain quality, and balance quality control with the desire to fill orders quickly. And if merchants accept returns, they have to manage their reverse logistics to accommodate one-of-a-kind products.

Here's a look at some companies that sell custom products and the strategies they employ.

## The Mattress of Your Dreams

To get the perfect night's rest, you need your perfect mattress. That's the theory behind Helix Sleep, a New York-based company that sells custom mattresses and offers a "100 Night Sleep Trial" with a money-back guarantee.

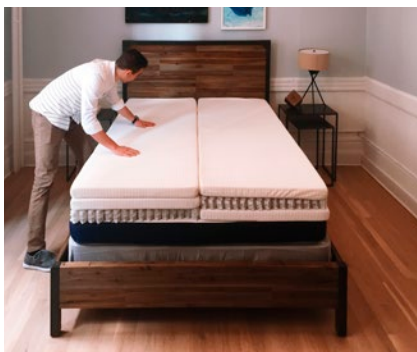

**A tight logistics process lets Helix Sleep deliver custom-made mattresses directly to consumers with free shipping, free returns, and a 100 night sleep trial.**

Helix Sleep operates a Manhattan showroom where customers can try out mattresses in person. But most customers buy online. They start by taking a short quiz that captures details about their size and weight, firmness preference, and preferred sleep position.

"We run that through our algorithms and match them to a specific construction that maximizes how they sleep," says Jerry Lin, the company's co-founder. Helix can make a mattress to one set of specifications or cater to a couple with a mattress made differently on the right and left.

Based on the specs, Helix produces instructions and routes them to one of its manufacturing partners, located in the Midwest, on the West Coast, or in the Southeast. The order goes to the manufacturer nearest the customer, making delivery as fast as possible. It takes about 24 hours to make the mattress, which then goes into a box about the size of a set of golf clubs for shipping via UPS.

"The mattress is rolled up like a big Tootsie Roll and wrapped in plastic packaging," Lin says. "Once you cut open the packaging, the mattress expands like a loaf of bread."

Planners at Helix never know what sleep needs they'll have to accommodate next. But that's no problem when it comes to managing inventories of foam that suppliers use to build the mattresses. The company uses a small variety of foam sheets,

layering them in different ways to suit different needs.

To assure quality, Helix works closely with its manufacturing partners to source raw materials. "We tell our manufacturers the type of foam, springs, and fabrics to buy, and from which suppliers," Lin says.

Another set of partnerships helps Helix execute its reverse logistics strategy. If a mattress fails the 100 Night Sleep Trial and the customer wants a refund, Helix consults its database of local charities that have agreed to pick up mattresses.

It costs less to donate an unwanted mattress than to throw it away or recycle it, Lin says. If there's no willing charity close enough for a pickup, Helix arranges for a local removal company to take the mattress to a recycling center.

That process could change in the future. "As we grow, there may be ways to build out our internal logistics to provide the returns ourselves," Lin says.

## If the Shoe Fits

Come wedding season, custom orders make up about 30 percent of the business at Hourglass Footwear. But even the company's non-custom products are one of a kind.

Based in Seattle, Hourglass is an e-commerce merchant that sells hand-painted shoes for women. The website offers five styles—platform, stiletto, mid-heel, flat or Danskø clog—in a variety of designs. Make your choice, indicate your size, and one of Hourglass's artists will paint the design on a pair of blank shoes and add a triple layer of sealant.

But if you want to slip your feet into something unique, call or e-mail Hourglass and tell managing director Lisa Ström what you have in mind. You might also provide



a photo for reference. Ström relays that information to the artist who seems best suited to your job.

“The artist makes a pencil sketch, so the customer gets to suggest changes,” Ström says. “After approval, the artist paints.”

The peak period for custom orders runs from April through July or August. “The rest of the year custom orders are about 15 percent of our business,” Ström says.

Because Hourglass makes each pair of shoes to order, including the ones based on standard designs, it keeps little ready-to-ship inventory. Ström accumulates orders and distributes them to her artists, along with blank shoes, at a weekly meeting in Seattle. Artists also give her the finished shoes for shipping to customers via the U.S. Postal Service.

A few Hourglass artists live outside the Seattle area. “I send them the blank shoes, they get them painted and sealed, then send them directly to the customer,” Ström says.

Ström keeps a small inventory of blank shoes in stock, with the most popular sizes for each style. She orders other sizes from suppliers as needed.

### Slow Motion

With a process like that, Hourglass can't offer a quick turnaround. “We can usually fulfill orders in about two weeks, although I ask customers to allow two to four weeks,” Ström says. That provides some leeway if things get busy, or if she needs to special order a size.

Customers rarely return shoes for reasons related to quality, Ström says. If a pair simply doesn't fit, a customer can return it for a refund. Popular designs in common sizes usually resell without trouble. Other pairs go to Hourglass's Ready to Ship page, where they're offered at a discount.

Since it's just about impossible to resell shoes adorned with the lyrics to someone's wedding dance song, or the face of a cherished pet poodle, custom-designed shoes come with a no-return policy.



**At Hourglass Footwear, every pair of hand-painted shoes is made to order, which means little inventory is ever ready to ship.**

## More Tricks of the Custom Trade

One big challenge that comes with customization is the need to acquire sophisticated inventory management systems, says Paul D'Arrigo, vice president of information technology at Spend Management Experts in Atlanta.

Consider an e-commerce bicycle merchant that uses the same seat on 10 different configurable models. Say the company has five seats in stock, and the inventory management system shows that five units of each bike are available for sale on the website. But when one bike sells, the system can't take just that unit out of inventory. “They have to immediately update all 10 bikes to quantity four, because they only have four seats left,” D'Arrigo says.

When customization involves assembling components to meet each customer's demand, companies also must decide where that assembly will take place.

D'Arrigo has seen some new companies outsource all their assembly to third-party logistics firms or, if products are large and heavy, to white-glove delivery carriers. But after a while, the merchant might notice that just a few configurations account for half the sales. “They can pre-make those and handle delivery themselves, and just custom-build the ones that are ordered more rarely,” he says.

Saddle Creek Logistics Services makes a specialty of customization. For example, for one client, the company embroiders names on scrubs, lab coats, and other medical garb. For employees who do this personalization, accuracy and quality assurance are important parts of the job. “We might work with our client to make sure the specifications for fonts and the color matches are accurate on their website,” says Bobby Hays, general manager for Saddle Creek's Fort Worth, Texas, warehouse and fulfillment operations.

“At times, our staff will reach out directly to a consumer to make sure that what they think they ordered is what they actually ordered,” he says. An associate might notice, for instance, that the consumer ordered black embroidery on a black garment, or that the embroidery color doesn't look good against the background. The associate can work directly with the consumer to find a better solution.

Although most consumers understand that customization might require extra time, Saddle Creek designs its processes to fill custom orders quickly. “If we can turn the order around same day or even next day, it sends a positive message to the consumer that they're doing business with a reputable company,” Hays says.



**Saddle Creek offers customization services including embroidering names on medical garb.**



**Alton Lane custom-tailors men's clothes. Satisfying requests for just about any kind of fabric makes inventory management a special challenge.**

## Suit Yourself

At Alton Lane, a purveyor of custom menswear, the opportunities for men to choose their own look are almost endless. Fabrics, shirt cuffs, collars, lapels, trouser pleats—even the color of the button stitching—are yours to decide.

And, of course, there's the fitting. A man who visits one of Alton Lane's showrooms, located in cities across the United States, steps into a 3D body scanner, where 32 sensors capture his measurements in detail. Online shoppers provide their own measurements, or send Alton Lane a favorite garment for reference.

The scanner is just one token of how Alton Lane is taking custom menswear into the 21st century. "We're marrying an old school philosophy and skill set with modern day demand for fast delivery," says Kyle Sjarif, vice president of operations and analytics at Alton Lane in Richmond, Virginia.

"Fast" in this case means four to six weeks—a snail's pace when measured in Amazon time, but speedier than the



traditional cycle for custom menswear, and necessary when producing one-of-a-kind products with a supply chain that circles the world.

Once a customer completes an order, Alton Lane's enterprise resource planning (ERP) system transmits it to a manufacturing partner in Thailand, Vietnam, or Germany. The company orders its fabric from suppliers in Europe, South America and the United States.

Most customers choose fairly standard fabrics in colors such as navy, black, and charcoal. "But we do have customers who want something truly unique to themselves, whether it's a fabric with chips of diamond in it or a purple cashmere suit," Sjarif says.

### The Purple Cashmere Challenge

The need to satisfy requests for just about any kind of fabric makes inventory management a special challenge. The solution is to procure fabric only when it's needed for specific orders. "We won't keep five suits' worth of purple cashmere fabric on hand," Sjarif says.

Alton Lanes uses air freight to ship fabric to its three factories, which produce the garments and then ship them—also via air—to a 3PL's distribution center (DC) in Richmond. The DC then ships orders to customers.

While Alton Lane builds several quality control measures into its transactions with supplier partners, some human error is unavoidable, especially when you're working across language barriers, Sjarif says. A few years ago, for example, the company transmitted an order for a black tuxedo to its factory in Thailand.

"Our translation mechanism had been broken for a few days, and our supplier sent mislabeled fabric—it was burgundy fabric that was supposed to be for a black tuxedo." Employees at the factory didn't catch the error.

Obviously, technology plays a key role in the effort to modernize the relationship between a man and his tailor. When Alton Lane started in 2009, it relied largely on e-mail and scanned documents to communicate with its factories. Since then, it has worked with those partners to develop more automated processes, with system-to-system integration.

"It even involves figuring out if they have a system," Sjarif says. "And if they don't, what kind of system can we put in place to allow for us to talk to each other quickly and efficiently?"

Under the old model, a man would make four or five trips to a tailor for successive fittings and consultations. "We're trying to make that modern and mainstream for today's world," Sjarif says. ■

# 2018

## SHIPPERS

CONFERENCE AND TRANSPORTATION EXPO

APRIL 29 - MAY 1 | ORLANDO, FL

Build *YOUR* Own Experience

BUILD

NETWORK

STRATEGIZE

ENGAGE

IMPROVE

LEARN



### Build Your Own

# EXPERIENCE

Join fellow shippers April 29 - May 1 at the 2018 NASSTRAC Shippers Conference Transportation and Expo to hear from leaders and change-makers. We are excited to announce several changes this year that will provide the insights you need to improve your business.

#### A FEW HIGHLIGHTS INCLUDE:

- A streamlined schedule, including moving the NASSTRAC Golf Mixer to a new time slot
- Additional dedicated hours for networking opportunities with sponsors & exhibitors on our newly designed Expo Floor
- New, robust educational content designed to allow for you to choose the topics and sessions that align with your needs, including:
  - Deep Dive Session workshops
  - Hear opening keynote speaker: Chris Spear, President and CEO at American Trucking Associations as he discusses his vision for the transportation industry and improving our nation's infrastructure.

Visit [nasstrac.org/conference](http://nasstrac.org/conference) for the latest updates and to register today.

Got 3PL challenges?

Get free expert solutions at [inboundlogistics.com/3pl](http://inboundlogistics.com/3pl)

# 6

SUPPLY CHAIN TERMS

## **CREATING THE BUZZ**

Word! Brush up on the latest supply chain and logistics terms so you can hold your own at the next industry conference. By Gary Frantz

**BLOCKCHAIN.  
SIMPLICITY AS  
(SAAS).**

**AUGMENTED  
THE BI-MODAL  
ELECTRIC  
AUTONOMOUS**

**A SERVICE**

**REALITY.**

**SUPPLY CHAIN.**

**TRUCKS**

**VEHICLES.**

The business of logistics and supply chain has always been characterized by a full complement of interesting, unique, sometimes confusing, and now and again mind-boggling terms to explain the fundamental process of moving goods from Point A to Point B.

Over time, this laundry list of terms logisticians use to describe what they do, and how they do it, has proliferated, particularly as technology takes a front and center role in how we plan, execute, and analyze logistics.

Every year, more definitions and descriptors enter the logistics lexicon; 2017 was a banner year for technology-related terms.

We saw a year where “software in the cloud” helped to accelerate the “digitization” of supply chains. Meanwhile, “the Amazon effect” forced retailers to rethink the need for “brick-and-mortar” stores, and the “Internet of Things” connected everything to everybody over the “last mile.” And we know all this happened because “big data” analytics told us so.

Phew!

What does 2018 have in store? *Inbound Logistics* asked several industry watchers what topped their list of terms that will dominate conversations this year. Some answers were serious, others tongue-in-check. But the consensus of our unscientific poll is that the supply chain community in 2018 will see the following six terms continue to emerge and gain traction in our conversations:

# 1.

**BLOCKCHAIN.** This was by far the biggest vote-getter. Known more as the foundation for crypto-currencies such as Bitcoin, blockchain jumped

into the supply chain vernacular with the formation of two global alliances, the Dutch Blockchain Coalition and the Blockchain in Transport Alliance.

In January 2018, IBM and Maersk turned up the volume, announcing a joint blockchain-based venture to develop a “global trade digitization platform built on open standards and

designed for use by the entire global shipping ecosystem.”

Blockchain is a distributed ledger technology that establishes a shared, immutable record of all transactions that take place within a network and then enables permissioned parties access to trusted, accurate data in real time. The technology holds promise for digitizing global trade processes and enabling participants, in a privacy-secured environment, to collaborate and execute end-to-end global shipping transactions with real-time visibility.

The concept is gaining traction, and the technology will be disruptive, but full development could take five to 10 years, according to a recent Gartner Inc. report co-authored by Bart De Muynck, research director for transportation technology in Gartner’s supply chain research group.

“Right now, the reality is hyped,” noted De Muynck in an interview. “For transportation, blockchain is much more applicable if you can embed it around exiting technologies and processes. It won’t replace an app or database, but it can elevate transparency, visibility, and security.”

# 2.

**SIMPLICITY AS A SERVICE (SAAS).** The

increasing complexity of supply chain operations and

the technologies upon which they rely has dramatically raised the stakes as businesses struggle to successfully deploy solutions. What have been massive enterprise software deployments can be months and sometimes years in the making, and once fully operational, not deliver anywhere near the value originally promised.

The complexity and time-to-value problems have been key drivers behind software developers’ shift to an original SaaS model: software-as-a-service, or software “in the cloud.” The updated definition: Simplicity as a Service.

It’s described succinctly as “enabling customers to achieve their desired outcomes in an ever-changing business

environment with less time, effort, cost, risk and resources,” writes Adrian Gonzales, president of supply chain consultancy Adelante SCM. This new version of SaaS “goes beyond making user interfaces more intuitive and easy to use and deployments faster and simpler,” he says. “It’s about helping companies respond more quickly and intelligently to changing customer requirements, competitive threats, regulations, and other market forces.”

It’s also why business models for third-party logistics providers, software vendors, and consultants are converging.

# 3.

**AUGMENTED REALITY.** Virtual

reality (VR) headsets are all the rage with video game players.

Augmented reality represents applying this technology to supply chain business processes, particularly in warehouses.

Virtual reality headsets or other wearable technology, such as Google glasses, aid order-picking operations and work such as assembling products on pallets. These wearables use sophisticated software to blend digital imagery and information with the user’s environment to help workers visualize and perform tasks more accurately and efficiently.

# 4.

**THE BI-MODAL SUPPLY CHAIN.**

This is a big topic for 2018, according to De Muynck. As the transformation to

a digital business ecosystem matures, companies will find themselves running both “analog” (Mode 1) and “digital” (Mode 2) supply chains—or bi-modal.

An analog supply chain is the traditional model, where product is physically placed in a store and displayed for customers. They walk around the store, find and pick the product they want, pay for it, then carry it out of the store.





Many logistics companies are using virtual reality and simulation exercises to train workers.

In the digital supply chain, customers find the product and place the order online. The system directs the order to the nearest warehouse. Robots and other automated systems pick, pack, and label the order, sending it on a conveyor to shipping.

In the fully digital supply chain of the future, a drone or autonomous vehicle would then take the shipment and deliver it to the customer. In this automated process, human hands do little or no touching. And customers can go online at any time and view the status of the order.

Today, “retailers have to support both, not one or the other,” says De Muynck. People still physically handle and move the product in the warehouse, while incorporating more automated systems, such as robotics and other automated picking equipment, as the business of fulfillment becomes increasingly digital.

A lot of industry buzz centers around the effect driverless vehicles will have on the truck driver shortage.



“This is where new technology comes in, supported by artificial intelligence and machine learning,” he adds. “It helps workers process more volume more efficiently and quickly.”

**5. ELECTRIC TRUCKS** and autonomous vehicles. Both these developments made great strides in 2017 and will continue to dominate conversations as they move closer to broad commercial adoption.

Following its introduction late last year, Elon Musk’s Tesla Semi electric truck has drawn orders from the likes of Anheuser Busch, Walmart, Sysco, and PepsiCo, as well as fleets including J.B. Hunt and Schneider.

And Tesla is not the only player. Truck manufacturers such as Daimler

Freightliner and Navistar also are well into the development of both electric trucks and those with autonomous operating systems. With a projected battery range of 300 to 500 miles pulling a typical 80,000 pounds of trailer and freight, it’s likely these soon-to-come electric tractors will see initial deployment in short-haul runs and city pickup and delivery routes.

**6. AUTONOMOUS VEHICLE (AV)** technology is expected to be deployed for both traditional diesel-powered

trucks as well as electric. The National Highway Safety Administration defines five levels of vehicle automation, from zero (no automated operating features) to five (fully automated operation).

Most of the truck-platoon demos rolled out last year were Level 1 applications; automation that still has some level of driver assistance and/or intervention. At Level 2, trucks would operate with automated steering—accelerating and braking while driving on the highway—but most likely still with a driver in the cab.

As vehicle-to-vehicle communications and other enabling technologies such as adaptive cruise control are further refined and developed, and regulatory issues are ironed out, the prospect of “ platoons” of two or more trucks running close together in sequence, particularly for long stretches of less-crowded highways between cities, will arrive.

This technology development offers great promise for improved fuel efficiency, safety, and quality of life for the driver.

Other terms, such as the Uberizing of freight brokerage, the “gig” or shared economy, predictive analytics, disintermediation, and the ever-growing influence of e-commerce will continue to redefine how we talk about what’s happening in supply chain and logistics.

One thing is for sure—the supply chain thesaurus will be adding a lot more pages. ■

**ALIGN4GROWTH**



**STRATEGY**



**SALES**



**MARKETING**



**OPERATIONS**

**30+ Educational Sessions**

**Learn from Shippers of  
Leading Brands**

**Best Practices in Marketing,  
Communications, Sales**

**Expand Your Network in  
Transportation & Logistics**

**Comprehensive Expo of  
Valuable Solutions**

# LOGISTICS MARKETING & SALES CONFERENCE

**RELEVANT TOPICS INCLUDE:**

Buyer-Driven Strategies  
Sales & Marketing Integration  
CRM & Customer Relationships  
Digital Marketing & Social Selling  
Lead Gen & Referral Marketing  
Content Marketing  
Marketing & Sales Automation  
Compensation-Driven Outcomes  
Inbound & Outbound Strategies  
Media Relations & Advertising  
Metrics & Data-Driven Strategies  
Measurement & ROI

**June 10-12, 2018  
Fort Myers, Florida**

**Get Info & Register  
at [TMSAtoday.org](http://TMSAtoday.org)**



**Got 3PL challenges?**

Get **free** expert solutions at [inboundlogistics.com/3pl](http://inboundlogistics.com/3pl)



## Casebook | by Emma James

### Sourcing Packaging Globally Boxes Up Savings

Hungry to reduce food packaging costs, Church's Chicken flies the domestic coop and finds an economic supplier on the other side of the world.

**C**hurch's Chicken takes a strategic approach to supply chain management with a bottom-line goal of finding the lowest possible cost and most efficient way to get products to franchisees. When Church's found an area of opportunity for cost savings in sourcing paperboard for food boxes, it collaborated with Huhtamaki, a global food packaging specialist, to source the paperboard used in producing the restaurant's boxes and cartons. Huhtamaki was able to produce the paperboard more cost effectively than domestic companies, and help Church's reduce associated paperboard costs by four to five percent.

At quick-service restaurants, it's not always easy to find the perfect recipe for serving quality products at affordable prices. These restaurants meet a need for a pleasant dining experience with good food at a low price point, often in neighborhoods that may be struggling economically. For Church's Chicken, keeping its promise of delicious, high-quality fried chicken—right here, right now—is paramount.

Founded in 1952 in San Antonio, Texas, Church's is one of the world's largest quick-service restaurant

chicken chains. The menu focuses on fried chicken, honey-butter biscuits made from scratch, and classic home-style sides. Church's, along with its sister brand Texas Chicken, operates more than 1,650 locations in 27 countries and international territories with system-wide annual sales totaling more than \$1 billion.

Christopher Ward, senior vice president of global supply chain for Church's, leads the company's supply chain, purchasing, distribution, and logistics teams. All these functional areas impact what Ward views as a



**Church's Chicken found a global supplier that could cost effectively supply the paperboard it uses in food boxes.**

key responsibility of his team: to help franchisees meet fulfillment challenges so they can focus instead on driving sales, pleasing customers, and building the brand.

Ward and his team regularly examine Church's entire supply chain network, not only to ensure that the system is on track, but also to identify areas of opportunity. "We look at what we're currently doing, plan the work, and work the plan," says Ward.

To find the most effective way to get products to the restaurants at the lowest cost, Ward and his team work closely and collaboratively with distributors and suppliers.

At Church's, Ward leads supplier diversity programs and strives to understand the way distributors and suppliers operate. He then works with them to find ways to operate the business more effectively, which, in turn, helps Church's save money and improve products.

Ward spends a lot of time with suppliers, but not with the sole intention of repeatedly asking them to reduce prices. Rather, he works to establish true partnerships.

### **Cost Savings Opportunities**

A recent network analysis revealed an area of opportunity for cost savings in sourcing paperboard used to manufacture food boxes. The solution Ward found to producing more economical boxes came as a result of what he calls "literally thinking outside the box."

"We started looking not just domestically, but at the entire world as a source for products we need for our restaurants," he says.

Taking a world view led Ward to Huhtamaki, a global company with a network of 74 manufacturing units, 24 sales offices, and a presence in 34 countries. Huhtamaki helps quick-service restaurants with their paper and plastic product needs, and specializes in food

and drink packaging. The company produces the paperboard Church's needs at a more cost-effective price than domestic suppliers.

Church's did not make the decision to source paperboard globally without a great deal of due diligence. Church's assembled a cross-functional team to analyze the advantages and disadvantages of using Huhtamaki as a paperboard product supplier. Ward also visited its manufacturing facility in Sweden and saw firsthand the company's state-of-the-art equipment and technology.

How is it possible for a product manufactured across the world to be more cost effective than one sourced locally? Huhtamaki attributes its success to its network of manufacturing units in three distinctive technologies—paper, plastic, and molded fiber. Its diverse product offering provides the breadth necessary to cost-effectively serve companies such as Church's, according to Scott

Stuckenschneider, vice president of supply chain for Huhtamaki.

In fact, Huhtamaki views its global operation as a competitive benefit to the company and the customers it serves.

“We see opportunities everywhere in the food and drink markets, just as our customers do,” says Stuckenschneider. “And we are well placed to help act on those opportunities. Our broad global reach is matched by our established presence and experience in many markets—particularly those that are fast growing.”

### Assuring Quality and Low Cost

While cost is an important factor in selecting a vendor, quality is equally critical. “At Church’s, we work closely with our partners to assure quality and that mitigates risk,” says Ward. “We tested the Huhtamaki products extensively before rolling them out to our entire system.”

Huhtamaki is able to deliver market-leading products because of its own rigor

and commitment to quality. “We have strict requirements related to inbound raw materials,” says Stuckenschneider. “Customers expect we will provide good product stewardship, and meet quality standards not just some of the time, but all of the time.”

Global shipping can become complex, but robust sourcing and logistics practices can simplify operations. For example, Huhtamaki uses a transportation management system for increased visibility and decision support, working through its third-party logistics provider Transplace.

Although Huhtamaki outsources some logistics functions, Stuckenschneider and his team are involved in selecting modes and carriers. Church’s transportation process encompasses a range of modes—from ocean freight for inbound raw materials to full truckload, less-than-truckload, and intermodal for other products. When choosing transportation, Huhtamaki evaluates all modes in all lanes.

Stuckenschneider makes it a priority to have contingency plans in place so that regardless of any glitch in the process, either locally or globally, Church’s maintains supply chain continuity. “We have the capacity to source contingency raw materials from a wide range of suppliers for our customers,” says Stuckenschneider.

### Tasty Results

Since sourcing paperboard packaging through Huhtamaki, Church’s expects to reduce its paperboard costs by four to five percent, a significant savings considering it spends more than \$10 million annually with Huhtamaki.

For Huhtamaki, working with Church’s Chicken has been a positive experience as well. “It is always great to work with companies that think strategically,” says Stuckenschneider. “Church’s is constantly looking for ways to improve its entire supply chain, and is not afraid to make the necessary changes to achieve those improvements.” ■



Quick-service restaurant Church's Chicken constantly evaluates its supply chain network to identify ways to deliver products to franchisees efficiently and cost effectively.

3PL

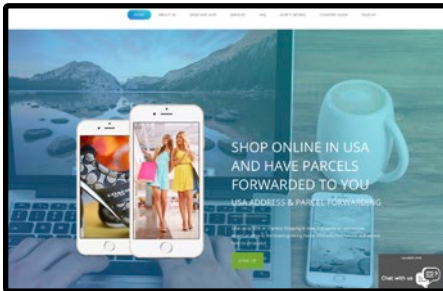

**American eBox • www.americanebox.com**

American eBox—eLogistics and Warehouse Services. Providing logistics services such as freight inspections, product prep (labeling, poly-bagging, kitting/bundling), and storage, as well as international return services, fulfillment, and flexible solution-based warehousing, all of which is managed with the underlying objective to provide the highest level of care and quality to every logistics project. American eBox provides logistics services to global manufacturers, retailers, and suppliers. Harness the power of information technology and streamline logistics. Our warehouse management system provides real-time visibility and online shipping controls at your fingertips. Cost-effective, Efficient, Trusted.

**Lynden • www.lynden.com**

Over land, on the water, in the air—or in any combination—Lynden has been helping customers solve transportation problems for almost a century. Operating in such challenging areas as Alaska, Western Canada and Russia, as well as other areas around the globe, Lynden has built a reputation of superior service to diverse industries.



EDUCATION

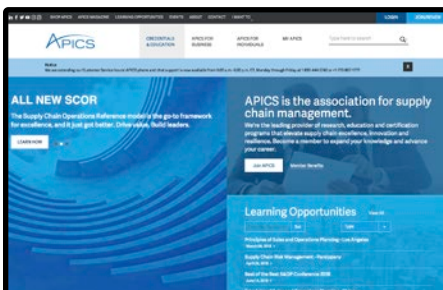

**APICS • www.apics.org**

Supply chain management never stops advancing—and neither should supply chain professionals or their organizations. APICS helps develop supply chain talent and elevate end-to-end supply chain performance. From education and certification to benchmarking and best practices, APICS sets the industry standard. Together with its members, partners and customers, APICS is united in its commitment to global supply chain excellence, innovation and resilience—achieved one person and one supply chain at a time.

**East Carolina University, College of Business  
www.ecu.edu**

Supply chain management has become increasingly significant as firms recognize the importance of aligning the supply chain and production system with how a firm strategically competes in the global marketplace. East Carolina University's concentration in operations and supply chain management (OSCM) prepares students for careers in sourcing, operations, and logistics. OSCM graduates have career choices as managers of purchasing, distribution, inventory, logistics, operations, quality, and supply chains. The OSCM curriculum also prepares graduates to sit for the Certified Purchasing Manager examination.



**IN THIS SECTION:**

**Education - Reverse Logistics**

**EDUCATION**



**Michigan State University**  
**www.cel.cmich.edu/onlineMBA/logistics**

Central Michigan University's online Master of Business Administration degree with an emphasis in logistics management is an accelerated 34-credit degree program taught completely online that takes two years to complete. The degree's nine core courses—including logistics management, integrated logistics strategy, lean logistics, and risk-based logistics networks—form a solid foundation in business administration.

**University of St. Francis • www.stfrancis.edu**

An MBA with a concentration in Supply Chain Management lets you work on projects that combine practical industry knowledge with business acumen and innovation skills. Do you want to lead your enterprise by discovering ways to serve customers well using advanced transportation, information, and supply chain practices? The MBA with Supply Chain Management concentration at the University of St. Francis is definitely the choice for you. Have fun, network with professionals, and benefit from flexible program options and experiential learning.



**University of Washington, College of Engineering**  
**www.supply-chain-transportation.uw.edu**

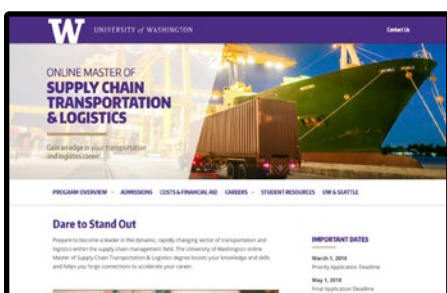

The Supply Chain Transportation & Logistics Master's degree gives you the technical skills and big picture perspective to separate yourself from the pack. Learn from world-class faculty and industry leaders through a work-compatible online curriculum housed at the University of Washington's premier College of Engineering, ranked 15th in public engineering graduate schools by *U.S. News & World Report*. Gain an edge in your transportation and logistics career.

**REVERSE LOGISTICS**

**American eBox • www.americanebox.com**

American eBox—eLogistics and Warehouse Services. Providing logistics services such as freight inspections, product prep (labeling, poly-bagging, kitting/bundling), and storage, as well as international return services, fulfillment, and flexible solution-based warehousing, all of which is managed with the underlying objective to provide the highest level of care and quality to every logistics project. American eBox provides logistics services to global manufacturers, retailers, and suppliers. Harness the power of information technology and streamline logistics. Our warehouse management system provides real-time visibility and online shipping controls at your fingertips. Cost-effective, Efficient, Trusted.

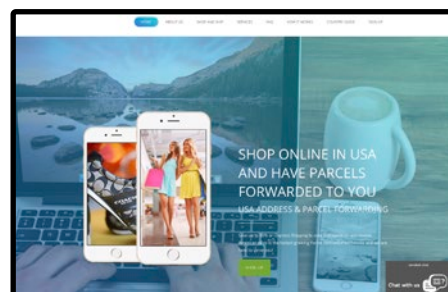

# WhitePaperDigest

Industry experts amass supply chain management best practices and skill sets, and invest in new research and evaluation tools. Now you can benefit. *Inbound Logistics* has selected this collection of whitepapers that will give you a jump on important supply chain issues. For more information on any of these whitepapers, visit the Web sites listed below.



---

## Evans Distribution Systems

---

**TITLE:** *Not Your Mama's 3PL*

**DOWNLOAD:** [bit.ly/notyourmamas3PL](http://bit.ly/notyourmamas3PL)

**SUMMARY:** How do you define a 3PL? Definitions abound, especially as the capabilities of a 3PL have shifted dramatically throughout the years. But the legal definition of a 3PL was hammered down in 2008, defined as a person who solely receives, holds, or otherwise transports a consumer product. Find out what differentiates a 3PL by downloading this whitepaper.

---

## J.B. Hunt

---

**TITLE:** *A Leaner Supply Chain*

**DOWNLOAD:** [bit.ly/leanerSCWP](http://bit.ly/leanerSCWP)

**SUMMARY:** Supply chains are inherently complex and interconnected. And the greater the number of products produced or destinations for goods, the greater the potential for complexity and the greater the necessity for systematic, enterprise-level approaches to preserve value for the company at every link in the supply chain. Download this whitepaper to discover how a more integrated supply chain can contribute value to your company.

---

## SEKO Logistics

---

**TITLE:** *Supply Chain Visibility*

**DOWNLOAD:** [bit.ly/SEKOWp](http://bit.ly/SEKOWp)

**SUMMARY:** The emergence of supply chain software providers in the cloud that span the entire supply chain is happening now. This shift will provide smaller hard goods manufacturers and distributors more efficient and collaborative supply chains, which ultimately lower cost and increase profitability. Get SaaS savvy by reading this whitepaper.





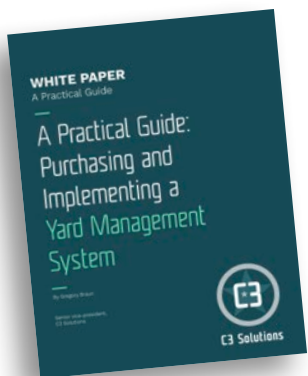
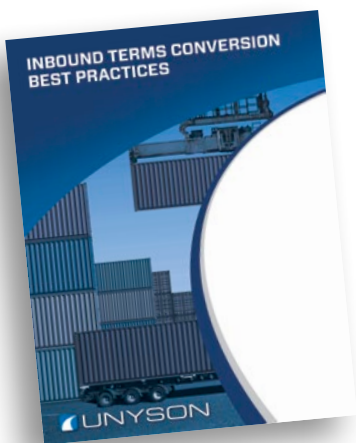

---

## Purolator International

---

**TITLE:** *Winning the Battle for E-Commerce Last-Mile Excellence*

**DOWNLOAD:** [bit.ly/PurolatoreCommerce](http://bit.ly/PurolatoreCommerce)

**SUMMARY:** Amazon is driving consumer delivery expectations. The online giant is the reason people now expect two-day-and-under delivery times. What's a retailer not named Amazon to do? Make your last mile your best mile. Last-mile service is the make-or-break part of a transaction. When a customer is either pleased with delivery services or disappointed if something goes wrong, the appreciation (or the blame) goes not to the logistics provider but to the retailer. There are a host of options and strategies to improve last-mile service, but to make your last-mile service a true competitive advantage, you'll need two things: technology and the right logistics provider. Find out more by downloading this free whitepaper.

---

## Unyson

---

**TITLE:** *Inbound Terms Conversion Best Practices*

**DOWNLOAD:** [bit.ly/UnysonBestPractices](http://bit.ly/UnysonBestPractices)

**SUMMARY:** Many companies remain unaware of how much inbound freight costs them because these charges are buried in the prices they pay for the goods. "Collect" payment terms allow companies to pay for their own inbound transportation costs rather than their vendors, resulting in greater control over their network. For details, download this whitepaper.

---

## Amber Road

---

**TITLE:** *4 Keys to Digitizing Your Global Supply Chain*

**DOWNLOAD:** [bit.ly/AmberRoadGlobalSC](http://bit.ly/AmberRoadGlobalSC)

**SUMMARY:** Global trade is a fast, complex environment that many organizations struggle to keep up with. Its ever-changing nature means that your supply chain processes and technology must transform just to keep up the pace. Digitization enables full transformation. Digitizing your supply chain enables four key methods of transformation leading to value, including: collaboration, automation, analytics, and flexibility. Download this eBook today and discover how your organization can yield value through supply chain digitization!

---

## C3 Solutions

---

**TITLE:** *Purchasing and Implementing a Yard Management System*

**DOWNLOAD:** [bit.ly/C3onYMS](http://bit.ly/C3onYMS)

**SUMMARY:** You will find everything you need to know about purchasing and implementing a Yard Management System in this practical guide. It aims to help inform the decision to implement a YMS – from investigation to scoping to vendor selection and implementation. The whitepaper covers: who needs a Yard Management System, specific areas where YMS can optimize operations, what to look for when evaluating a YMS, vendor evaluation checklist, ROI considerations, and a blueprint for successful implementation.

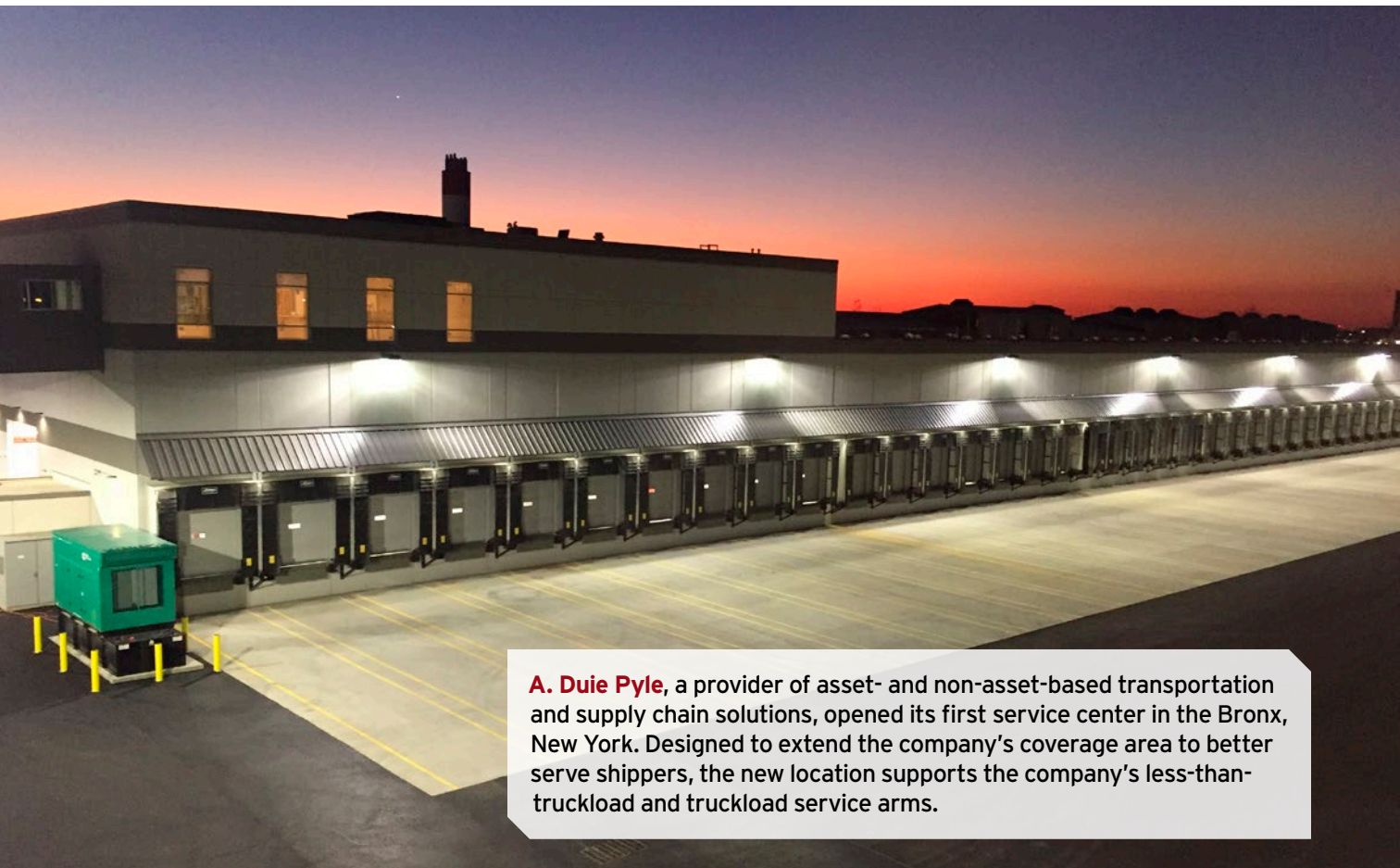

**A. Duie Pyle**, a provider of asset- and non-asset-based transportation and supply chain solutions, opened its first service center in the Bronx, New York. Designed to extend the company's coverage area to better serve shippers, the new location supports the company's less-than-truckload and truckload service arms.

### // Services //

Air cargo company **Worldwide Flight Services** opened a temperature-controlled facility in Copenhagen to improve its ability to handle pharmaceutical cargo. The facility has the capacity to store up to 16 cargo units and features separate temperature chambers offering both 35.6-46.4°F and 59-77°F environments. Each lane in the building is equipped with an electronic rollerbed system to expedite the handling of pharma shipments.

**Delta Cargo** added Dusseldorf airport to its network of stations receiving IATA's Center of Excellence for Independent Validators (CEIV) pharma logistics certification. Delta has seven CEIV-approved facilities in Europe connected to its largest cargo operation in Atlanta, which is also CEIV certified. In addition to Dusseldorf, the CEIV stations include Amsterdam, Brussels, Frankfurt, Milan, Paris, and Rome, creating a trans-Atlantic CEIV network to the United States.

**Pilot Freight Services**, a provider of transportation and logistics services, opened a 65,000-square-foot warehouse in Piscataway, New Jersey, to enable Northeast shippers to meet the needs of their customers quickly and with flexibility. The new warehouse is close to multiple major airports and has access to the Port of New York and New Jersey.



◀ Transport and logistics company **Gebrüder Weiss** expanded logistics solutions for the automotive industry. With its Competence Cluster Automotive arm, the company analyzes shippers' specific requirements and develops solutions for manufacturers, suppliers, and dealers to manage the entire supply chain. Services include warehousing, procurement, and distribution logistics, encompassing just-in-time delivery to the factory and in-house logistics. The service arm also covers transnational regions as a regional freight forwarder.

## //Transportation//

The Helen Delich Bentley **Port of Baltimore** begins a roll-on/roll-off service to New Zealand and Australia in March 2018. The monthly service on **Hoegh Autoliners** starts in Baltimore then includes service to the ports of Auckland, Brisbane, Port Kembla, Melbourne, and Fremantle. The first sailing will be on the *Hoegh Jeddah*, which is scheduled to call on the Port of Baltimore in mid-March, 2018.

**American Airlines Cargo** is adding four new routes—to Budapest, Reykjavik, Prague, and Venice—to its international network, starting in May and June 2018. The airline is introducing service from Philadelphia to Budapest, Hungary, and Prague, Czech Republic; Chicago O'Hare to Venice, Italy; and Dallas/Fort Worth to Reykjavik, Iceland. The three European capital cities—Budapest, Prague, and Reykjavik—are new to the American network. Venice is currently connected to the United States via service to Philadelphia.

**Lufthansa Cargo** increased freighter services from Frankfurt, Germany, to Japan, adding two weekly freighters to Osaka. The additional flights complement the existing daily freighter from and to Tokyo-Narita, as well as Lufthansa passenger flights to Osaka-Kansai, Tokyo-Haneda, and Nagoya. The new route is operated from Frankfurt via Novosibirsk to Osaka on Wednesday and Friday, and adds to a total of 80 weekly flights into and out of the country, including the belly capacity on Lufthansa passenger aircraft and the carrier's cooperation capacity with ANA Cargo.

▶ Global logistics provider **Kuehne + Nagel** offers a new dedicated LCL seafreight service from Shanghai, China, to Chattanooga, Tennessee, to serve the increasing demand from automotive companies for small-volume shipments in high frequency to the greater Chattanooga region. The service enables shippers to reduce inventory levels through smaller order sizes and to source from different suppliers in smaller batches. The weekly sailing takes approximately 20 days from port to port, and Kuehne + Nagel is involved at all stages of cargo shipments, from origin to destination.



► **The Raymond Corporation** launched a virtual reality simulator to help train new and existing forklift operators. The Raymond Virtual Reality Simulator allows the operator to train in a simulated warehousing environment utilizing an existing Raymond forklift truck by plugging into the company's Simulation Port. The simulator allows operators to become familiar and comfortable with the forklift and its controls prior to operating within the physical warehousing environment, avoiding potential product and warehouse incidents.



## //Technology//

**Logility**, a provider of retail planning and collaborative supply chain optimization solutions, unveiled Dynamic Allocation and Replenishment, a new capability within *Logility Voyager Retail Optimization*. Retailers with multiple distribution centers can now automatically allocate and replenish merchandise to each store location or channel from any combination of distribution centers to boost inventory velocity and support each location's ability to meet financial plans.

Supply chain and omnichannel commerce solutions provider **Manhattan Associates** released a solution that gives retailers new insight into individual shopping experiences to provide improved, personalized service. Part of the *Manhattan Active Omni* platform, Manhattan Customer Engagement connects customer conversations on social media platforms with real-time order information. It combines unstructured data from customer conversations with structured order information to allow retailers to make instant service improvements.

**Info-X**, a logistics software solutions provider, integrated its new cloud-based transportation management system with electronic transaction platform **INTTRA's** booking engine, enabling communication between numerous parties across INTTRA's network. The new system accepts electronic bookings and shipping instructions from NVOCC customers, ensuring quicker cargo bookings and providing real-time cargo tracking and tracing.

**Logistyx Technologies**, a transportation management execution (TME) systems provider, partnered with **JDA Software Group** to offer an integrated parcel shipping solution for *JDA Warehouse Management* customers. The Logistyx TME solution automates the entire JDA parcel shipping process, from real-time order entry, carrier rating, and routing through pack verification, weighing, consolidation, labeling, and manifesting. Additional capabilities include address verification, party screening, ACE filing, labeling, export documentation, and instant tracking.



◀ **Liftomatic Material Handling**, a materials handling equipment manufacturer, introduced the Ergo-Matic line of portable drum handling equipment. The product family is modular and designed for efficient manual handling of a single drum in repetitive applications. The Ergo-Matic line features high-lift capability up to 36 inches, spark-resistant components for flammable areas, and double clamps for fiber and plastic drums.

//Products//

Radio frequency identification (RFID) solutions provider **Alien Technology** unveiled a handheld RFID reader with all-day battery life for use with the latest smart devices. The new ALR-S350 RFID reader is designed for heavy inventory tasks, letting supply chain owners quickly locate RFID tagged merchandise and immediately respond to customer requests. By including the RFID capability in the handheld sled device and separating the operating system, display, and communications technology into a smart device, it lets workers use their personal phone or tablet.

► **One Way Solutions** released a nestable plastic pallet that offers high capacity, low tare weight, and a reinforced perimeter for increased impact resistance. The pallet is designed for one-way export shipments, light- to medium-duty reuse, work-in-progress, storage, display, and distribution applications. The 40- x 48-inch pallet weighs 17 pounds, providing 2,500 pounds of dynamic capacity and 8,800 pounds of static capacity.

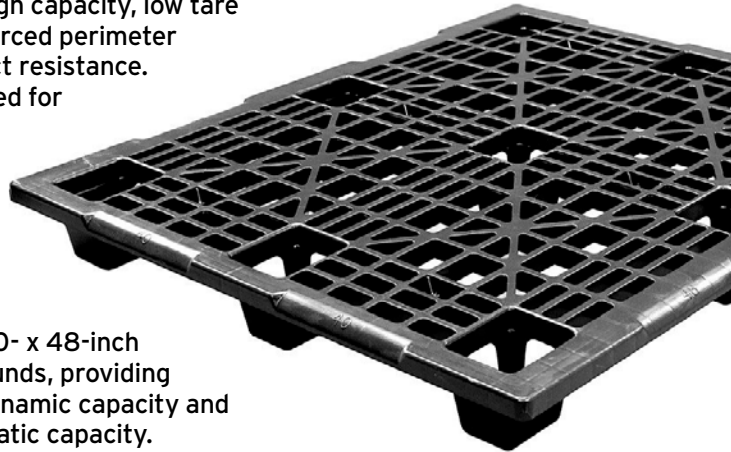

CAN EVERYONE ON YOUR TEAM SOLVE THIS?

$$ICC = \frac{C + T + I + W + X + (S - R1) + (O - R2)}{\text{Annual \$ Material Cost}}$$

If not, they should be reading this.

Spread the good news by getting your vendors, partners, and team members reading *Inbound Logistics*.

Point them to [bit.ly/get\\_il](http://bit.ly/get_il)

**inbound logistics**  
a THOMAS™ company



ICC=inventory carrying costs C=capital T=taxes I=insurance W=warehouse costs X=shrinkage S=scrap O=obsolescence costs R=recovery

Got 3PL challenges?

Get free expert solutions at [inboundlogistics.com/3pl](http://inboundlogistics.com/3pl)

# CALENDAR

## YOUR LOGISTICS DATEBOOK

APR  
9

MHI

### MODEX 2018

[modexshow.com](http://modexshow.com) | Atlanta, Ga. | APR 9-12, 2018

**AUDIENCE:** Manufacturing and supply chain professionals  
**FOCUS:** How Industry 4.0 and the Industrial Internet of Things is impacting supply chains; exploring the latest equipment and technology solutions from more than 850 providers; futureproofing your supply chain

**MAY 4, 2018** Los Angeles, Calif.

Los Angeles Area Chamber of Commerce

### World Trade Week Kickoff Breakfast

[worldtradeweek.com](http://worldtradeweek.com)

**AUDIENCE:** Supply chain stakeholders  
**FOCUS:** The evolution of trade in a digital world; importance and benefits of global trade on the local and national economy

**MAY 6-9, 2018** Nashville, Tenn.

Institute for Supply Management

### ISM 2018 Annual Conference

[ism2018.org](http://ism2018.org)

**AUDIENCE:** Supply chain managers  
**FOCUS:** Global supply chain challenges; managing complexity to increase competitive advantage; key steps in strategic sourcing; creating value through strategic partnerships; empowering women in supply management

**MAY 6-9, 2018** Charlotte, N.C.

Warehousing Education and Research Council

### WERC 2018: 41st Annual Conference for Logistics Professionals

[werc.org/2018](http://werc.org/2018)

**AUDIENCE:** Logistics and warehousing professionals  
**FOCUS:** Strategies for warehouse slotting and packaging optimization; designing the distribution center of the future; effective warehouse associate recruitment and retention approaches

#### CONFERENCES

**MAR 11-13, 2018** Tampa, Fla.  
International Warehouse Logistics Association (IWLA)

### 2018 IWLA Convention & Expo

[bit.ly/IWLA2018](http://bit.ly/IWLA2018)

**AUDIENCE:** Warehouse logistics stakeholders  
**FOCUS:** Motivating employees for continued growth; effective warehousing strategies; the latest in warehousing innovation; warehouse law; how to recruit, train, and retain today's workforce

**MAR 19-21, 2018** Charleston, S.C.  
Transportation & Logistics Council

### 44th Annual Conference: Education for Transportation Professionals

[tlcouncil.org](http://tlcouncil.org)

**AUDIENCE:** Supply chain, logistics, and transportation professionals  
**FOCUS:** Critical issues facing the transportation and logistics industry, including new laws and regulations, security, outsourcing, insurance and transportation contracts, international trade, loss prevention, and cargo loss and damage

**MAR 26-28, 2018** Orlando, Fla.  
Express Carriers Association (ECA)

### 22nd Annual MarketPlace 2018

[expresscarriers.org/marketplace](http://expresscarriers.org/marketplace)

**AUDIENCE:** Supply chain and logistics professionals  
**FOCUS:** Forming logistics partnerships; finding regional and specialized carriers that can provide a viable supply chain alternative; new technologies and transportation services

**APR 9-12, 2018** Atlanta, Ga.

Georgia Center of Innovation for Logistics

### 2018 Georgia Logistics Summit

[georgialogistics.com/summit](http://georgialogistics.com/summit)

**AUDIENCE:** Supply chain and logistics professionals  
**FOCUS:** Next-generation analytics for supply chains; top transportation industry takeaways; assembling logistics success for manufacturing; tackling operational visibility through technology

**APR 18-19, 2018** Atlanta, Ga.

Terrapinn

### Home Delivery World 2018

[bit.ly/homedelivery2018](http://bit.ly/homedelivery2018)

**AUDIENCE:** Retail logistics and supply chain professionals  
**FOCUS:** Strategies for optimizing product fulfillment, delivery, and customer satisfaction through supply chain, logistics, warehousing, and transportation operations; trends in delivery operations; building a sustainable logistics network

**APR 29 - MAY 1, 2018** Orlando, Fla.

National Shippers Strategic Transportation Council (NASSTRAC)

### 2018 Shippers Conference & Transportation Expo

[bit.ly/shippersexpo](http://bit.ly/shippersexpo)

**AUDIENCE:** Transportation, logistics, and supply chain professionals  
**FOCUS:** Managing and optimizing transportation operations; implications of a customer-driven supply chain and the innovations transforming freight transportation and logistics; creating a secure and compliant international supply chain; the basics of less-than-truckload transportation

#### SEMINARS & WORKSHOPS

**APR 26-27, 2018** Cambridge, Mass.

MIT Sloan Executive Education

### Supply Chain Strategy and Management

[bit.ly/MITsupplychainstrategy](http://bit.ly/MITsupplychainstrategy)

**AUDIENCE:** Logistics and supply chain professionals  
**FOCUS:** The next big trend in supply chain strategy, and the key skills required to be successful; how to better structure a company's supply chain strategy; guidelines for making strategic sourcing and make-buy decisions; how to integrate e-business thinking into supply chain strategy and management



**BEYOND CLAIM FILING**

A full collection of software applications that will enable you to easily handle and manage any type of claim.



TranSolutions

480.473.2453 • [TranSolutionsInc.com](http://TranSolutionsInc.com) • [Sales@MyEZClaim.com](mailto:Sales@MyEZClaim.com)

# CHIEF PROCUREMENT OFFICER SUMMIT

April 9-10, 2018 | Eau Palm Beach Resort & Spa | Palm Beach, FL

**Chief Procurement Officer Summit** is the premium forum bringing elite buyers and sellers together. As an invitation-only event, taking place behind closed doors, the Summit offers solution providers and procurement executives an intimate environment for a focused discussion of key new drivers shaping the industry.

The one-on-one business meetings provide access to leading procurement executives in North America with direct responsibility for procurement and purchasing. Through our internationally acclaimed one-on-one meeting methodology, the **CPO Summit** allows solution providers to grow your market, improve sales and win more business. Join industry experts and:

- Get access to premium event content, exclusive presentations and interactive panels
- Network with high level executives during formal and informal time such as cocktails and dinner hours!
- Target qualified buyers and shorten your sales cycle, through our pre-scheduled one-on-one meetings format
- Accomplish 6-12 months of standard sales efforts in just two days by reaching ultimate budget decision makers

For more information, please contact [kennethay@marcusevanscy.com](mailto:kennethay@marcusevanscy.com) or visit: <https://events.marcusevans-events.com/cpo-summit2018-1/>

**SAMPLE OF KEY TOPICS:**

- From Transactional to Transformational: Driving innovation, growth & value
- Going Digital: Strategies for accelerating procurement transformation
- Talent of the future: Addressing the changing skill set requirements in procurement
- Analytics in Action: Highlighting data-driven decision-making

**SAMPLE OF DISTINGUISHED SPEAKERS:**

- **Steven Nowak**, Vice President, Global Sourcing and Chief Procurement Officer, **Owens Corning**
- **Susan Grelling**, Vice President, Supply Chain Planning and Sourcing, Chief Procurement Officer, **Patterson Companies**
- **Andrea Greco**, Chief Procurement Officer, **CBRE Group**
- **Anu Saxena**, Senior Vice President & Global Head, Hilton Supply Management, **Hilton**



# RESOURCE CENTER

# 02.18

## INBOUND LOGISTICS WORKS FOR YOU!

### 3PLs

**Echo** **Cover 4**  
www.echo.com/fi/ibl 888-514-8376

**ELM Global Logistics** **pg. 21**  
www.elmlogistics.com 800-736-1771

**Lynden** **pg. 3**  
www.lynden.com 888-596-3361

**Matson Logistics** **pg. 18**  
www.matson.com 866-628-7663

**PLS Logistics Services** **pg. 22**  
www.plslogistics.com 888-814-8486

**R2 Logistics** **pg. 11**  
www.thebest3pl.com 904-394-4677

**RR Donnelley's DLS Worldwide** **pg. 7**  
www.dls-ww.com 888-757-0291

**Shippers Group** **pg. 37**  
www.shipperswarehouse.com 214-275-1060

### Career Development/Education

**APICS** **pg. 45**  
www.apics.org/cltd 800-444-2742

**East Carolina University** **pg. 46**  
www.ecu.edu/ldis 252-328-9600

**JobsinLogistics.com** **pg. 46**  
www.jobsinlogistics.com 877-562-7678

**Michigan State University Online** **pg. 41**  
msuonline.com/scmlogistics 855-286-1244

**University of St. Francis** **pg. 46**  
www.stfrancis.edu/movers 800-726-2600

**University of Washington** **pg. 43**  
www.supply-chain-transportation.uw.edu 206-221-6407

### Events

**Chief Procurement Officer Summit 2018** **pg. 77**  
www.cpo-summit.com 312-476-9918

**Georgia Logistics Summit** **Cover 3**  
www.georgialogistics.com/summit 912-963-2551

**NASSTRAC** **pg. 59**  
www.nasstrac.org/conference 202-367-1174

**TMSA Marketing and Sales Leadership Conference** **pg. 64**  
www.TMSAtoday.org 952-466-6270 x208

**Modex 2018** **Cover 2**  
www.modexshow.com 704-676-1190

**Logistics IT 3PL Central** **pg. 30**  
www.3plcentral.com 888-375-2368

**Freightgate** **pg. 13**  
www.freightgate.com 714-799-2833

**Transolutions** **pg. 77**  
www.transolutionsinc.com 480-473-2453

**Rail CN** **pg. 9**  
www.cn.ca 888-668-4626

**Real Estate Logistics/ Site Selection** **pg. 5**  
**Pharr International Bridge** **pg. 5**  
www.pharrbridge.com 956-402-4660

For a specific response, contact these advertisers directly. Please tell them you saw their ad in *Inbound Logistics*.

For faster service, go online: [inboundlogistics.com/rfp](http://inboundlogistics.com/rfp)



Use our Resource Center and let the information you need find you.

## INDEX

ADVERTISER	PAGE
3PL Central	30
APICS	45
Chief Procurement Officer Summit 2018	77
CN	9
East Carolina University	46
Echo	Cover 4
ELM Global Logistics	21
Freightgate	13
Georgia Logistics Summit	Cover 3
JobsinLogistics.com	46
Lynden	3
Matson Logistics	18
Michigan State University Online	41
Modex 2018	Cover 2
NASSTRAC	59
Pharr International Bridge	5
PLS Logistics Services	22
R2 Logistics	11
RR Donnelley's DLS Worldwide	7
Shippers Group	37
TMSA Marketing and Sales Leadership Conference	64
Transolutions	77
University of St. Francis	46
University of Washington College of Engineering	43

For a specific response, contact these advertisers directly. Please tell them you saw their ad in *Inbound Logistics*.

For faster service, go online: [inboundlogistics.com/rfp](http://inboundlogistics.com/rfp)

# Lexicon Laughs

By Gary Frantz

Ever feel like you need a translator just to have a conversation? Today, “software in the cloud” helps “digitize” supply chains, while the “Amazon effect” forces retailers to reevaluate “brick and mortar” and the “IoT” connects it all. Here are some terms we know you won’t hear around the conference room table...because we made them up.



## BIG LAKES

The next iteration of Big Data. It has become so massive and all encompassing that it’s now a giant data lake, surpassing human capacity to process it.



## ANGEL INVESTING

Tossing cash at a new logistics technology startup on a wing and a prayer.



## FIN TECH

A new blockchain application that downloads data from autonomous drones as they follow schools of sharks and calculate the projected harvest of fins needed to produce shark fin soup.



## PLATOONING

When a company of soldiers climbs into the back of a troop carrier, and an autonomous truck transports them to a military base.

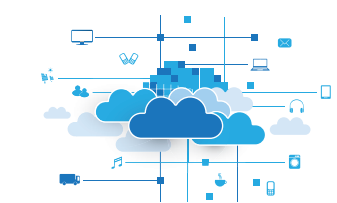

## INTERNET OF THINGS OR HOW LAZY CAN WE BE?

Using technology to send commands to other devices, appliances, or systems to do things so you don’t have to get up off the couch and do them on your own.



## SUPPLY CHAIN NIRVANA

A time in the future when all this glorious technology and data come together in a “seamless” end-to-end supply chain operation that tells us all is well and we don’t have to worry about a thing. (We won’t see it in our lifetime.)

# GEORGIA LOGISTICS SUMMIT

APRIL 9-12, 2018

GEORGIA WORLD CONGRESS CENTER | ATLANTA

## Connect, Compete and Grow your Business at the 2018 Georgia Logistics Summit

Now in its 10th year, the Georgia Logistics Summit brings together nearly 2,000 logistics and supply chain professionals from Georgia and beyond to network, share best practices, and learn about the latest trends in the industry.

Co-located with **MODEX**, the largest supply chain expo in North and South America, the Summit will bring exciting and engaging content to MODEX's more than 800 exhibitors from industry, commerce, and government.



**Gareth Joyce, SVP Airport Customer Service & Cargo**, will give the keynote address and take attendees on the **Delta Air Lines** journey to becoming a world class logistics organization centered around customer experience and brand fan creation. In addition, the Summit's more than 50 presenters will discuss industry leading topics ranging from economics to talent and technology. Attendees can also meet the future of the supply chain industry at our Student Showcase, learn about the technology changing the industry with our Tech Disruptors panel, and experience new product innovations through our 3rd annual Logistics Technology Showcase.

**This year's Summit will be the best yet. Secure your spot now!**

**REGISTER TODAY**  
[GeorgiaLogistics.com/Summit](http://GeorgiaLogistics.com/Summit)

a division of the Georgia Department of Economic Development

# You gotta be Shipping me.

## Dealing with too many carriers?

Let the experts at Echo Global Logistics handle load tender, track and trace, data management, order processing, invoice auditing, and bill payment for you. We move thousands of loads a day through our network of over 30,000 truckload carriers — regardless of season or spikes. And our leading edge technology gives you complete visibility into each shipment, from step-by-step tracking to custom reporting. When you're ready for a better, simpler shipping experience — **it's time to call ECHO.**

© Echo Global Logistics. All rights reserved

1 888 514 8376

[ECHO.com/fi/ibl](https://ECHO.com/fi/ibl)

**ECHO))**  
Transportation Simplified™

Got 3PL challenges?

Get free expert solutions at [inboundlogistics.com/3pl](https://inboundlogistics.com/3pl)